

Chain barriers

FA01928-EN

CE

EAC



CAT1DAGS
CAT1DACs

CAT2NNGS
CAT2NNCS

INSTALLATION MANUAL

EN

English



DEVICE MANUAL RELEASE

With the gearmotor released, the operator does not work.

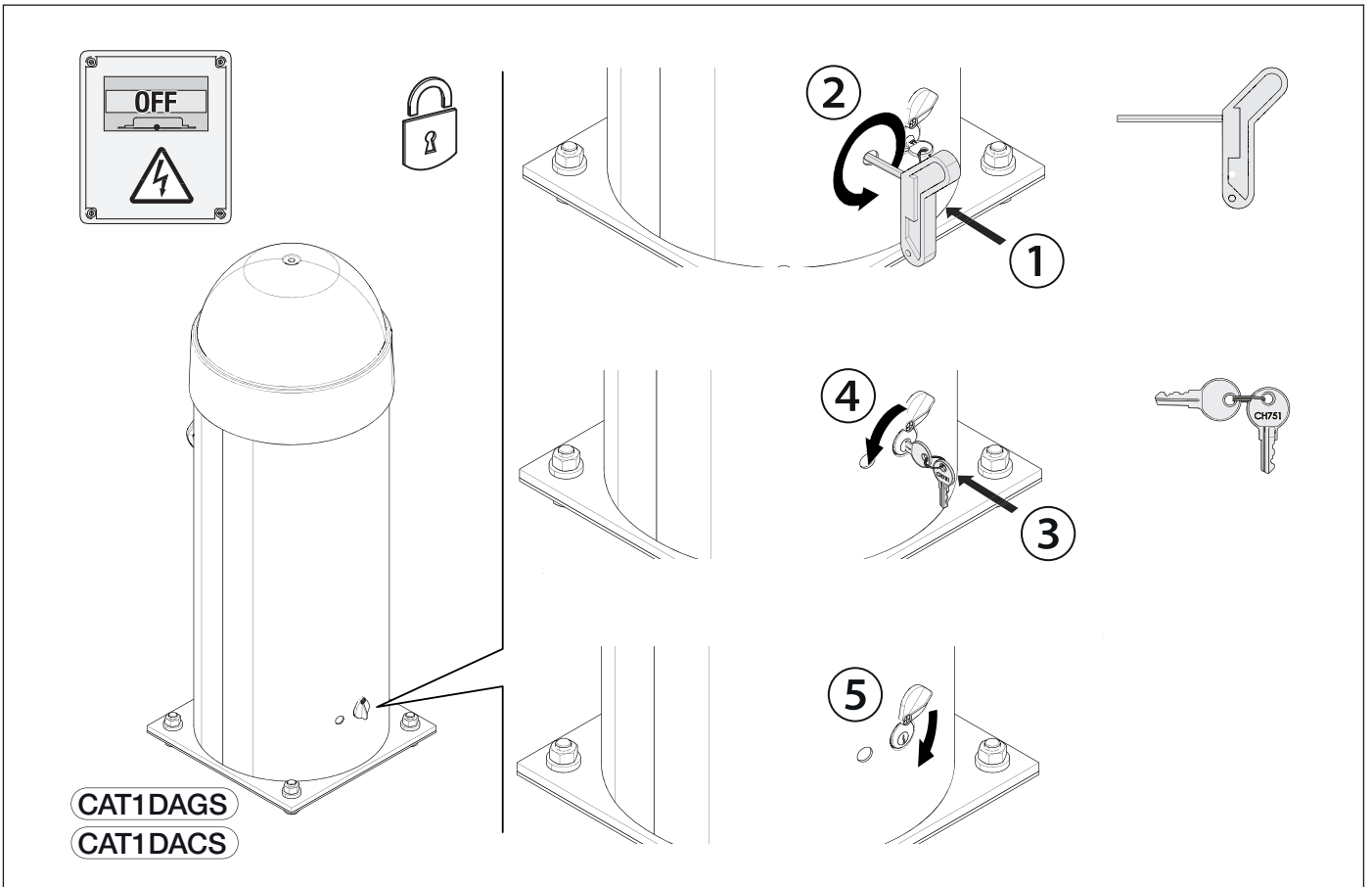
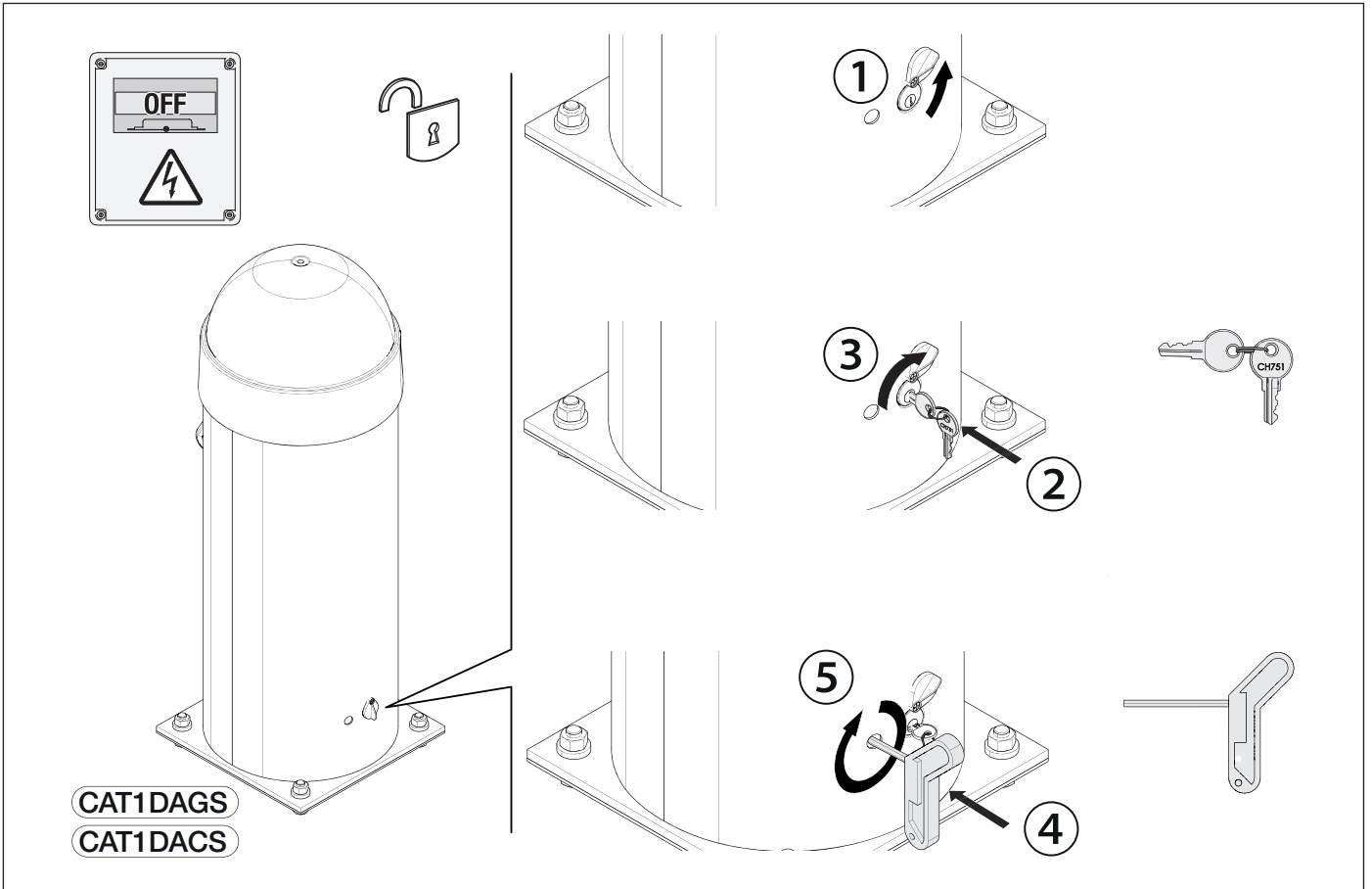

⚠ Important safety instructions.

⚠ Please follow all of these instructions. Improper installation may cause serious bodily harm.

⚠ Before continuing, please also read the general precautions for users.

Only use this product for its intended purpose. Any other use is hazardous. • The manufacturer cannot be held liable for any damage caused by improper, unreasonable or erroneous use. • This product is defined by the Machinery Directive (2006/42/EC) as partly completed machinery. • Partly completed machinery means an assembly which is almost machinery but which cannot in itself perform a specific application. • Partly completed machinery is only intended to be incorporated into or assembled with other machinery or other partly completed machinery or equipment thereby forming machinery to which the Machinery Directive (2006/42/EC) applies. • The final installation must comply with the Machinery Directive (2006/42/EC) and the European reference standards in force. • The manufacturer declines any liability for using non-original products, which would also void the warranty. • All operations indicated in this manual must be carried out exclusively by skilled and qualified personnel and in full compliance with the regulations in force. • The device must be installed, wired, connected and tested according to good professional practice, in compliance with the standards and laws in force. • Make sure the mains power supply is disconnected during all installation procedures. • Check that the temperature ranges given are suitable for the installation site. • Make sure that opening the automatic barrier does not constitute a hazard. • Do not install on slopes i.e. any surfaces that are not perfectly level. • Do not install the operator on surfaces that could yield and bend. If necessary, add suitable reinforcements to the anchoring points. • Make sure that no direct jets of water can wet the product at the installation site (sprinklers, water cleaners, etc.). • Make sure you have set up a suitable dual-pole cut-off device along the power supply that is compliant with the installation rules. It should completely cut off the power supply according to category III surcharge conditions. • Demarcate the entire site properly to prevent unauthorised personnel from entering, especially minors. • In case of manual handling, have one person for every 20 kg that needs hoisting; for non-manual handling, use proper hoisting equipment in safe conditions. • When the operator is being fixed in place, it may be unstable and overturn. Be careful and do not lean on it until it is fully fastened in place. • Use suitable protection to prevent any mechanical hazards due to persons loitering within the operating range of the operator. • The electrical cables must pass through special pipes, ducts and cable glands in order to guarantee adequate protection against mechanical damage. • Make sure that the moving mechanical parts are suitably far away from the wiring. • The electrical cables must not touch any parts that may overheat during use (such as the motor and transformer). • All fixed controls must be clearly visible after installation, in a position that allows the guided part to be directly visible, but far away from moving parts. In the case of a hold-to-run control, this must be installed at a minimum height of 1.5 m from the ground and must not be accessible to the public. • If not already present, apply a permanent tag that describes how to use the manual release mechanism close to it. • Make sure that the operator has been properly adjusted and that the safety and protection devices and the manual release are working properly. • Before handing over to the final user, check that the system complies with the harmonised standards and the essential requirements of the Machinery Directive (2006/42/EC). • Any residual risks must be indicated clearly with proper signage affixed in visible areas, and explained to end users. • Put the machine's ID plate in a visible place when the installation is complete. • If the power supply cable is damaged, it must be immediately replaced by the manufacturer or by an authorised technical support service, or in any case, by qualified staff, to prevent any risk. • Keep this manual inside the technical folder along with the manuals of all the other devices used for your automation system. • Make sure to hand over to the end user all the operating manuals of the products that make up the final machinery. • The product, in its original packaging supplied by the manufacturer, must only be transported in a closed environment (railway carriage, containers, closed vehicles). • If the product malfunctions, stop using it and contact an authorised support centre.

 The manufacture date is provided in the production batch printed on the product label. If necessary, contact us at <https://www.came.com/global/en/contact-us>.

 The general conditions of sale are given in the official CAME price lists.

Main points of danger for people

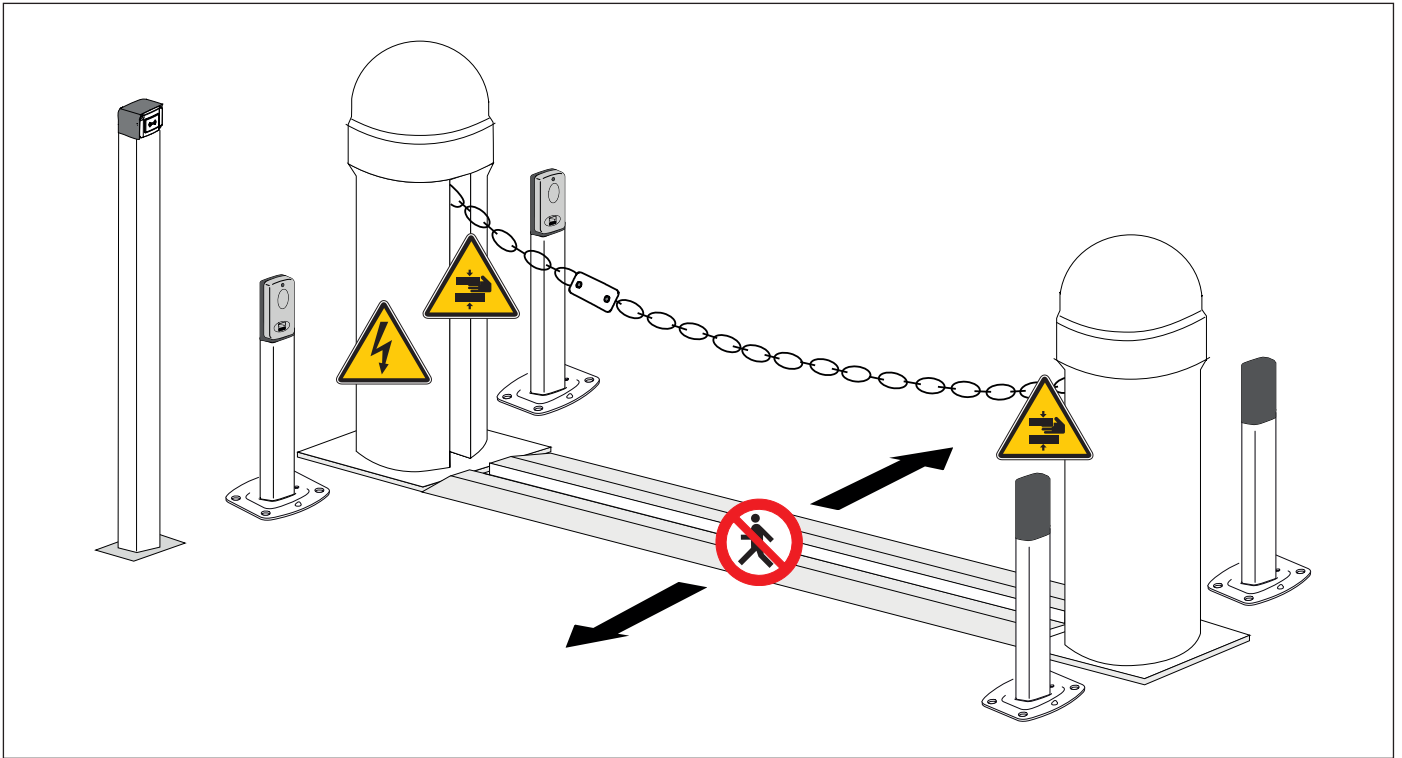

 Electrical hazard.

 Risk of trapping hands.

 No transiting.

DISMANTLING AND DISPOSAL

 CAME S.p.A. employs an Environmental Management System at its premises. This system is certified and compliant with the UNI EN ISO 14001 standard to ensure that the environment is respected and safeguarded. Please continue safeguarding the environment. At CAME we consider it one of the fundamentals of our operating and market strategies. Please follow these brief disposal guidelines:

DISPOSING OF THE PACKAGING

The packaging materials (cardboard, plastic, etc.) can be disposed of easily as solid urban waste, separated for recycling.

Before dismantling and disposing of the product, please always check the local laws in force.

DISPOSE OF THE PRODUCT RESPONSIBLY.

DISPOSING OF THE PRODUCT

Our products are made of various materials. Most of these materials (aluminium, plastic, iron and electrical cables) are classified as solid urban waste. They can be separated for recycling and disposed of at authorised waste treatment plants.

Other components (electronic boards, transmitter batteries, etc.) may contain pollutants.





These must be removed and disposed of by an authorised waste disposal and recycling firm.

It is always advisable to check the specific laws that apply in your area.

DISPOSE OF THE PRODUCT RESPONSIBLY.

PRODUCT DATA AND INFORMATION

Key

-  This symbol shows which parts to read carefully.
-  This symbol shows which parts describe safety issues.
-  This symbol shows what to tell users.
-  The measurements, unless otherwise stated, are in millimetres.

Description

CAT1DAGS

Pillar with 24 V gearmotor and built-in control panel.

CAT1DACS

Pillar with 24 V gearmotor and built-in control panel; galvanised steel post painted in customised RAL colour.

CAT2NNGS

Pillar with counterweight and chain hook.

CAT2NNCS

Pillar with counterweight and chain hook; galvanised steel post painted in customised RAL colour.

Additional accessories (not included)

001CAT-5

9 mm "Genovese" chain for passages up to 8 m.

001CAT-15

5 mm "Genovese" chain for passages up to 16 m.

001CAR-2

Above-ground chain protection track L = 2 m.

001CAR-4

Below-ground chain protection track L = 2 m.

Intended use

Managing public and private access

 Any installation and/or use other than that specified in this manual is forbidden.

Usage limitations

MODELS	CAT1DAGS	CAT1DACS
Max. passage width clearance 001CAT-5 (m)	8	8
Max. passage width clearance 001CAT-15 (m)	16	16

Technical data

MODELS	CAT1DAGS	CAT1DACS	CAT2NNGS	CAT2NNCS
Power supply (V - 50/60 Hz)	220-230 AC	220-230 AC	-	-
Motor power supply (V)	24 DC	24 DC	-	-
Board power supply (V)	24 AC	24 AC	-	-
Power (W)	540	540	-	-
Current draw (A)	2,7	2,7	-	-
Operating temperature (°C)	-20 ÷ +55	-20 ÷ +55	-20 ÷ +55	-20 ÷ +55
Cycles/hour	45	45	-	-
Protection rating (IP)	24	24	24	24
Insulation class	I	I	-	-
Weight (kg)	45	45	30	30
Storage temperature (°C)*	-20 ÷ +70	-20 ÷ +70	-20 ÷ +70	-20 ÷ +70
Average life (cycles)**	50000	50000	50000	50000

(*) Before installing the product, keep it at room temperature where it has previously been stored or transported at a very high or very low temperature.

(**) The average product life specified should be understood purely as an indicative estimate. It applies to normal usage conditions and where the product has been installed and maintained in compliance with the instructions provided in the CAME technical manual. The average product life is also affected, including significantly, by other variables such as, but not limited to, climatic and environmental conditions. The average product life should not be confused with the product warranty.

Fuse table

MODELS	CAT1DAGS	CAT1DACS
Line fuse	2 A-F	2 A-F
Accessory fuse	2 A-F	2 A-F

Description of parts

Barrier

- 1 Countersunk screw M12x30
- 2 Dome
- 3 Casing
- 4 Control panel
- 5 Frame
- 6 Gearmotor
- 7 Chain-winding pulley
- 8 Chain-retraction pulley
- 9 Chain
- 10 Anchoring plate
- 11 Anchoring bracket
- 12 Counterweight
- 13 Chain fastening lock
- 14 Limit-switch assembly
- 15 Limit-switch assembly guard
- 16 Lock for release
- 17 Release keys
- 18 Release lever
- 19 Chain fastening terminal
- 20 Hex-head screw M6x25
- 21 Entrapment-prevention safety microswitch

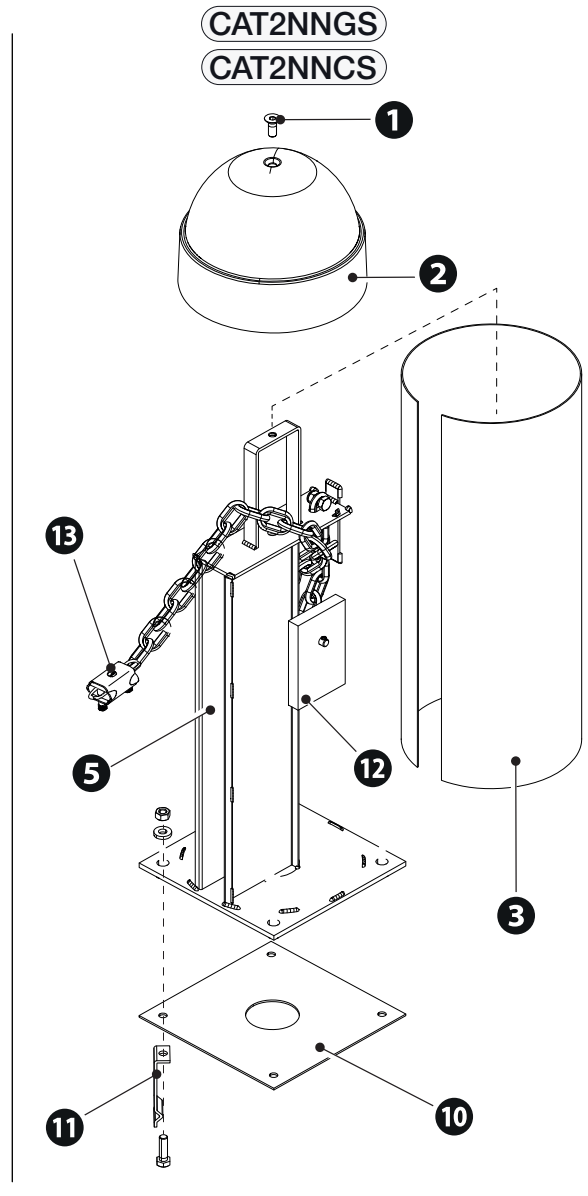
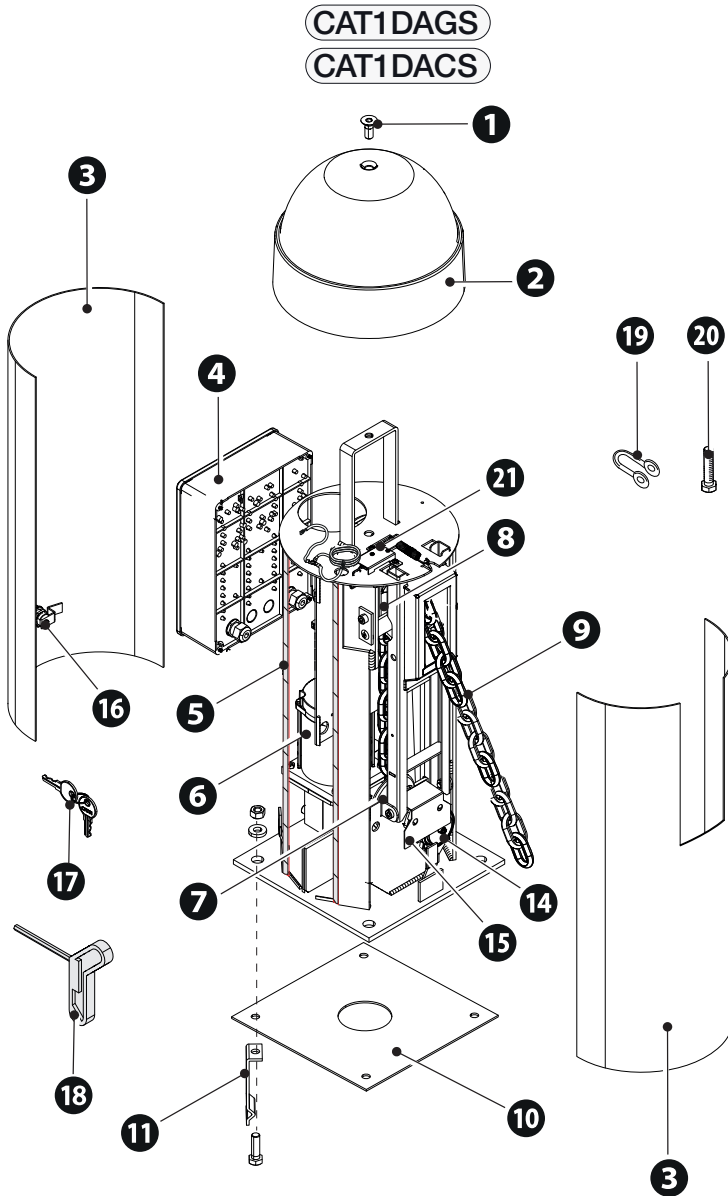

Control board

- 1 Terminal board for motor power supply
- 2 Terminal board for connecting the limit switches
- 3 Terminal board for connecting the safety devices
- 4 Terminal board for connecting control devices
- 5 Terminal board for connecting the antenna
- 6 Connector for plug-in radio frequency card (AF)
- 7 Memory roll card
- 8 Connector for the R700 or R800 decoding card
- 9 RSE card connector
- 10 Programming buttons
- 11 Terminal board for CRP connection
- 12 Terminal board for connecting the keypad selector
- 13 Terminal board for connecting the transponder selector switch
- 14 Terminal board for connecting the signalling devices
- 15 Accessories fuse
- 16 Terminal board for power supply to the control board

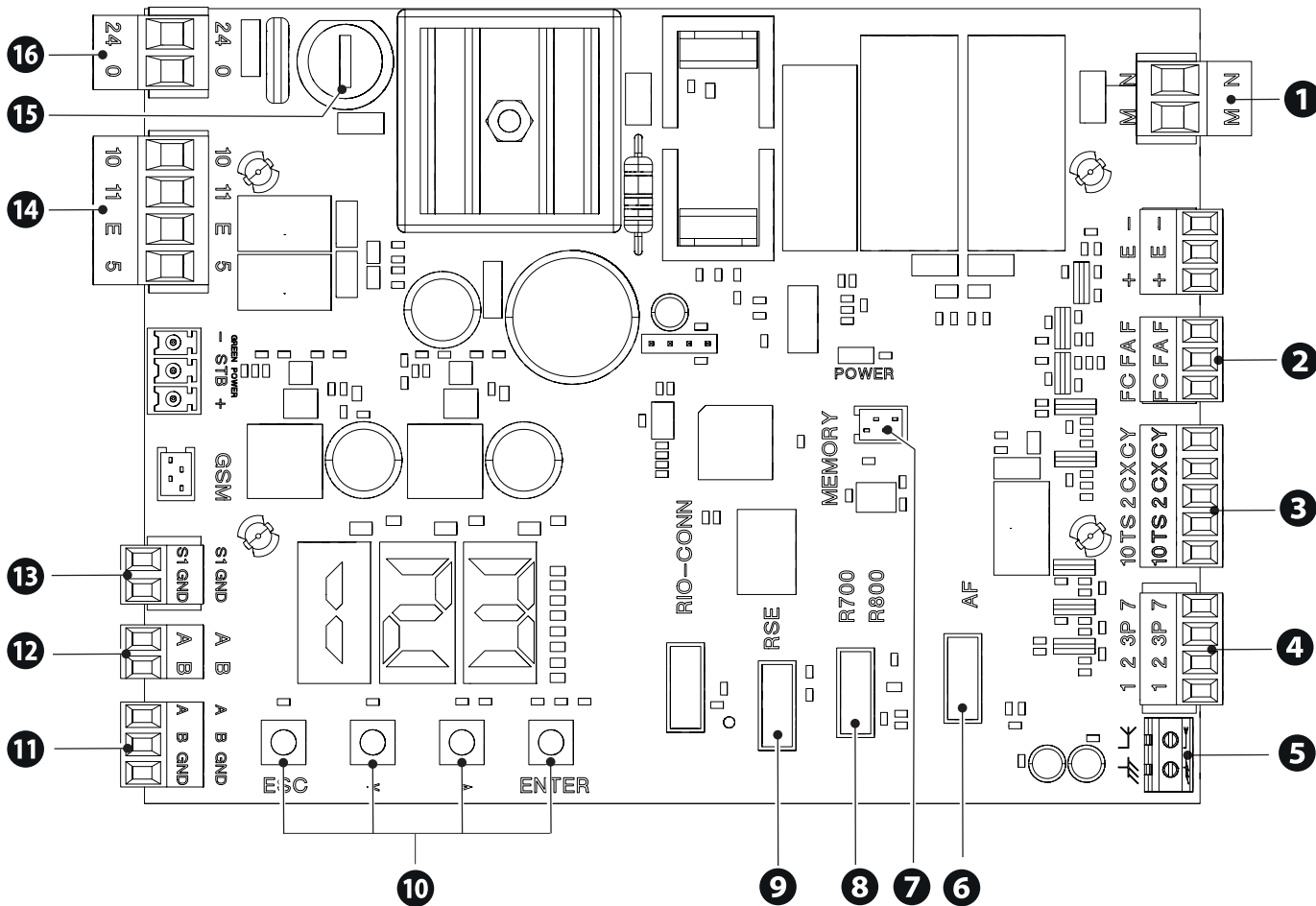

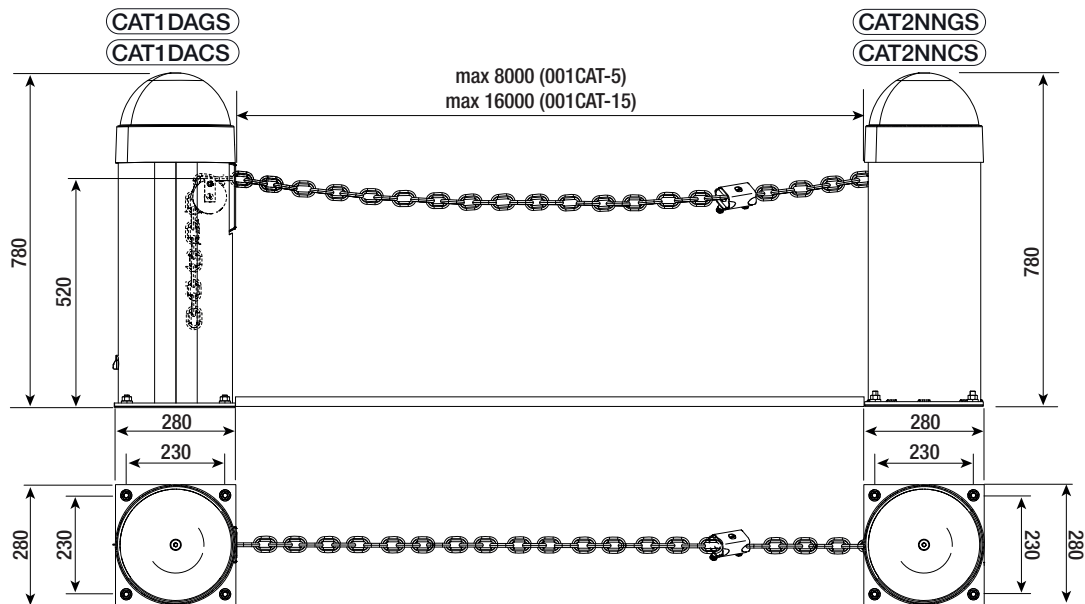

Cable types and minimum thicknesses

Cable length (m)	up to 20	from 20 to 30
Power supply 230 V AC	3G x 1.5 mm ²	3G x 2.5 mm ²
24 V AC/DC flashing beacon	2 x 1 mm ²	2 x 1 mm ²
TX Photocells	2 x 0.5 mm ²	2 x 0.5 mm ²
RX photocells	4 x 0.5 mm ²	4 x 0.5 mm ²
Command and control devices	*no. x 0.5 mm ²	*no. x 0.5 mm ²

* no. = see product assembly instructions - Warning: the cable cross-section is indicative and varies according to the motor power and cable length.

To connect the antenna, use RG58 cable (up to 5 m).

For installation in an outdoor environment, use cables with properties at least equivalent to those of type H05RN-F (with designation 60245 IEC 57).

For installation in an indoor environment, use cables with properties at least equivalent to those of type H05VV-F (designation to 60227 IEC 53).

If the cable lengths differ from those specified in the table, define the cable cross-sections according to the actual power draw of the connected devices and in line with regulation CEI EN 60204-1.

For multiple, sequential loads along the same line, recalculate the values in the table according to the actual power draw and distances. For information on connecting products not covered in this manual, please see the documentation accompanying the products themselves.

INSTALLATION

 The following illustrations are examples only. The space available for fitting the operator and accessories varies depending on the area where it is installed. It is up to the installer to find the most suitable solution.

In case of manual handling, have one person for every 20 kg that needs hoisting; for non-manual handling, use proper hoisting equipment in safe conditions. When the operator is being fixed in place, it may be unstable and overturn. Be careful and do not lean on it until it is fully fastened in place.

Preliminary operations

 If the flooring does not allow the device to be fastened in a solid and stable way, lay a cement slab.

Dig a hole for the foundation frame.

Set up the corrugated tubes needed for the wiring coming out of the junction pit.

 The number of tubes depends on the type of system and the accessories that are going to be fitted.

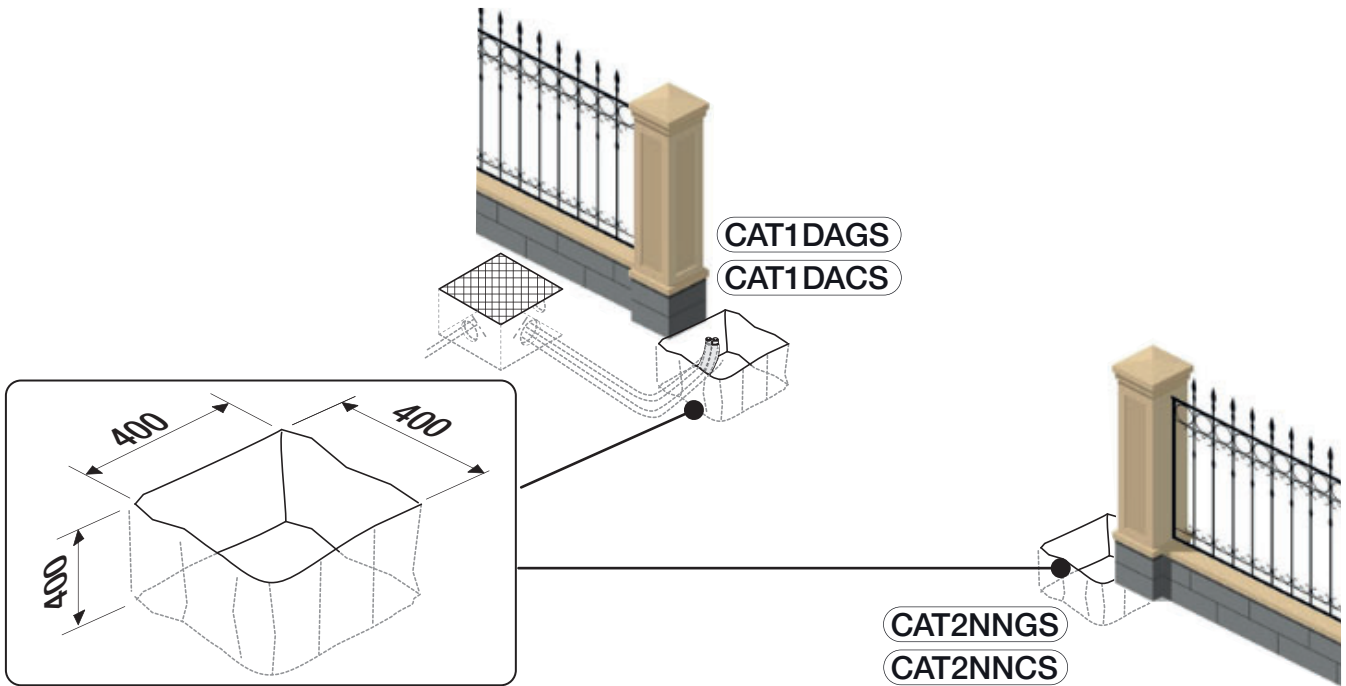

Dig a hole for the below-ground chain protection track (CAR-4).

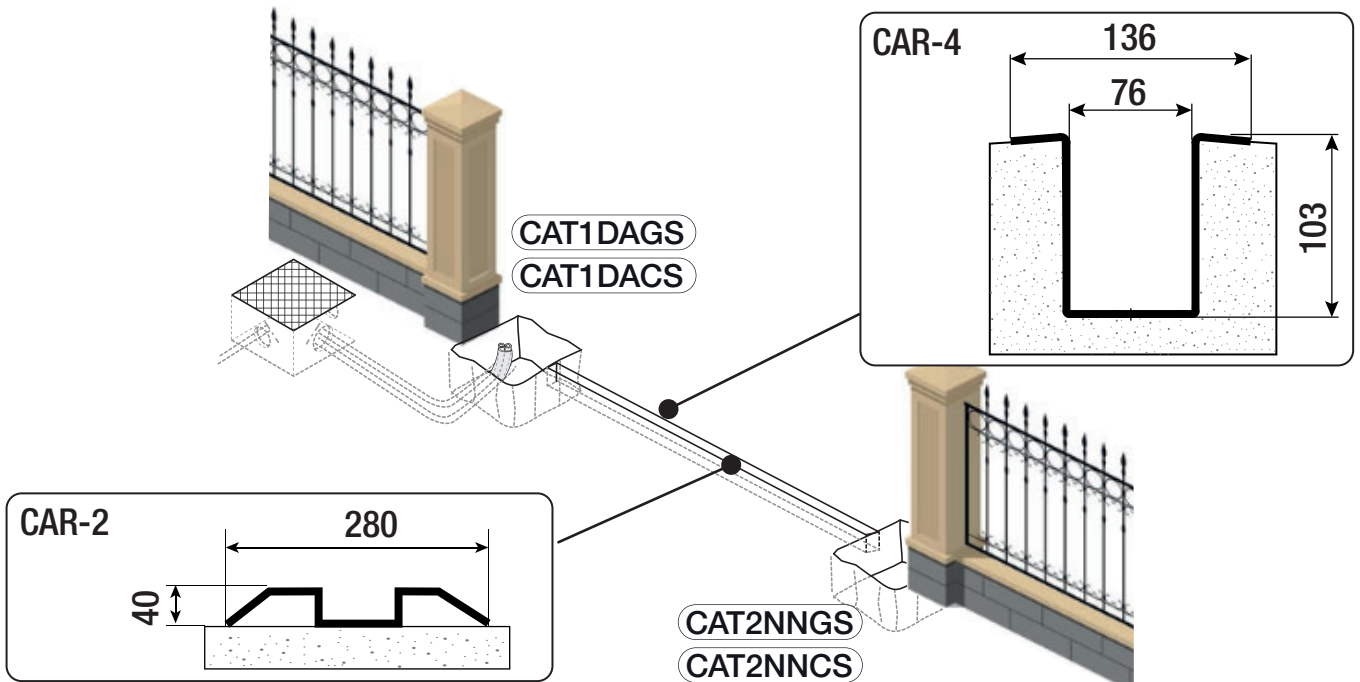

 In public areas, the CAR-2 and CAR-4 tracks must be clearly marked with suitable signs and/or painted with yellow-and-black diagonal lines, to warn against possible tripping and foot entrapment

Laying the anchoring plate

Set up a foundation frame that is larger than the anchoring plate.
Insert the foundation frame into the dug hole.

 If the above-ground track is used (001CAR-2), the foundation frame must protrude 50 mm above ground level.

Fit an iron cage in the foundation frame to reinforce the concrete.
Assemble the anchoring braces to the plate.

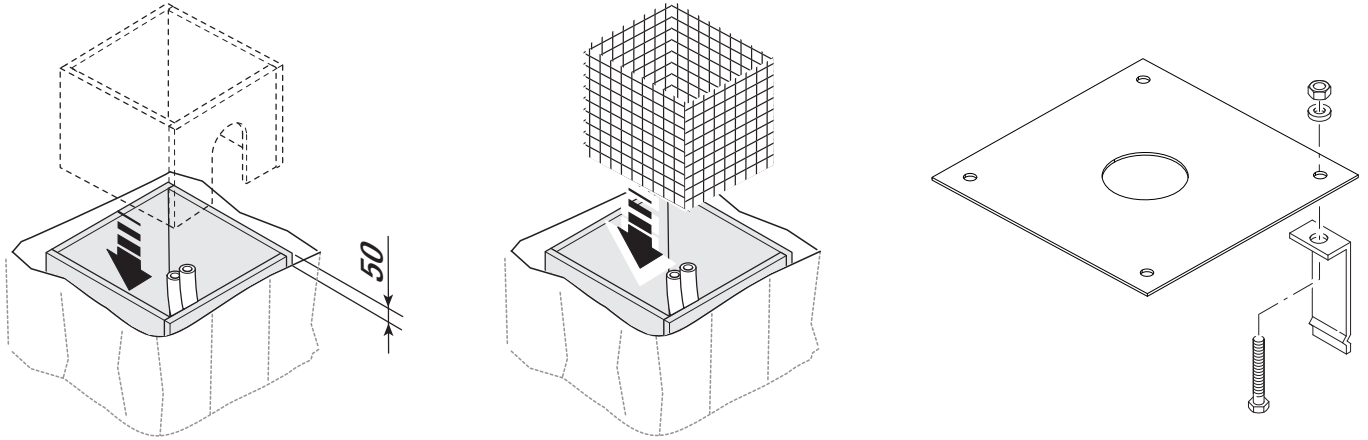

Fit the anchoring plate in the iron cage.

 The pipes must pass through the hole.

Cast cement into the foundation frame.

 The plate must be perfectly level and the screw threads completely above surface.

Wait at least 24 hours for the cement to dry.

Remove the foundation frame.

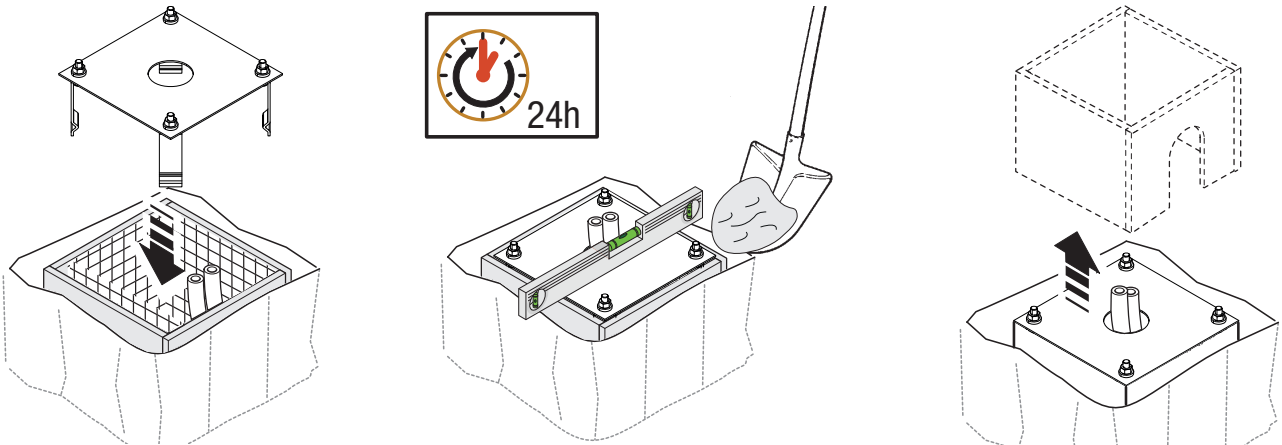

Fill the hole with soil around the concrete block.

Remove the nuts from the screws.

Insert the electrical cables into the tubes until they protrude by about 600 mm.

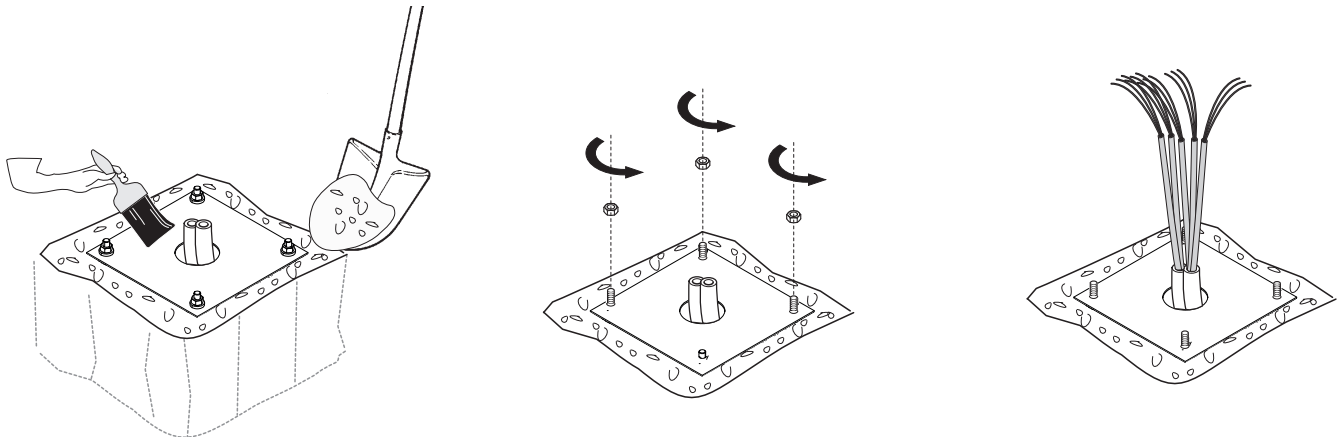

Fixing the pillars and chain protection track

Place the pillars on top of the anchoring plates and secure them using washers and nuts.

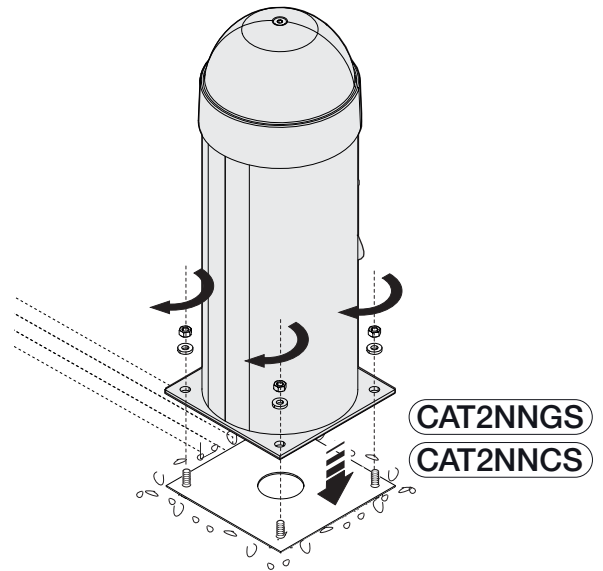
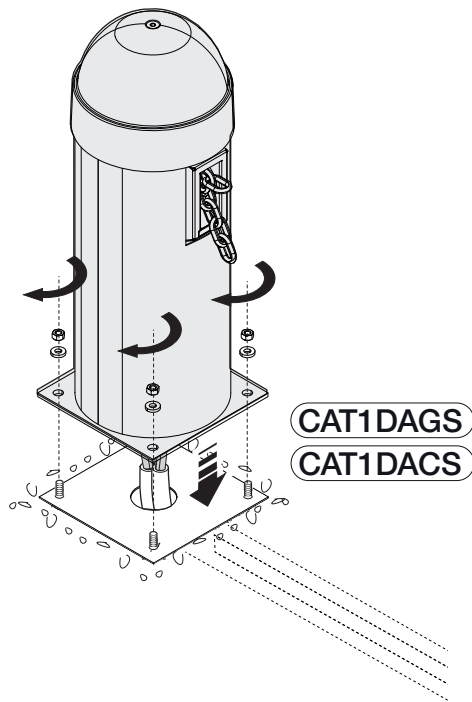

Remove the domes by unscrewing the screws.

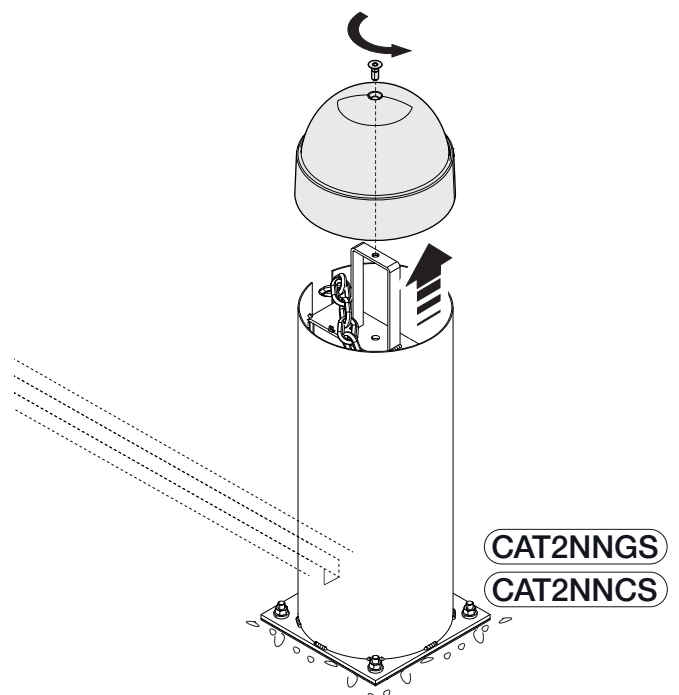
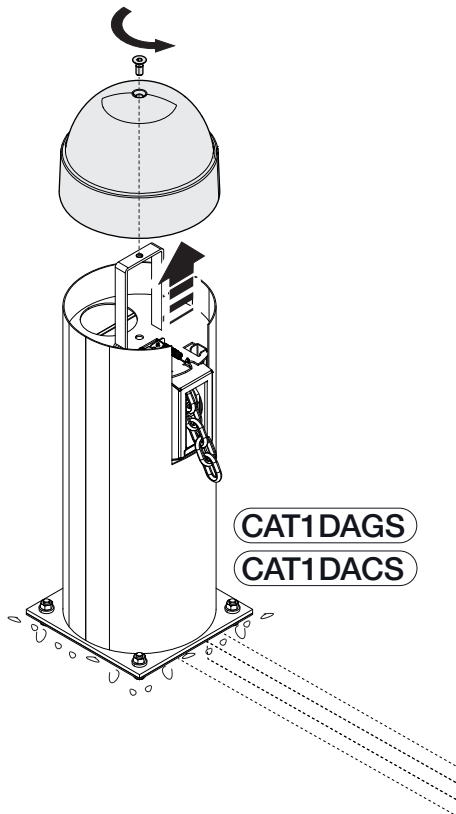

Remove the pillar casing (CAT1DAGS / CAT1DACs).
 Release the chain in the pillar (CAT2NNGS / CAT2NNCS) by removing the tie.

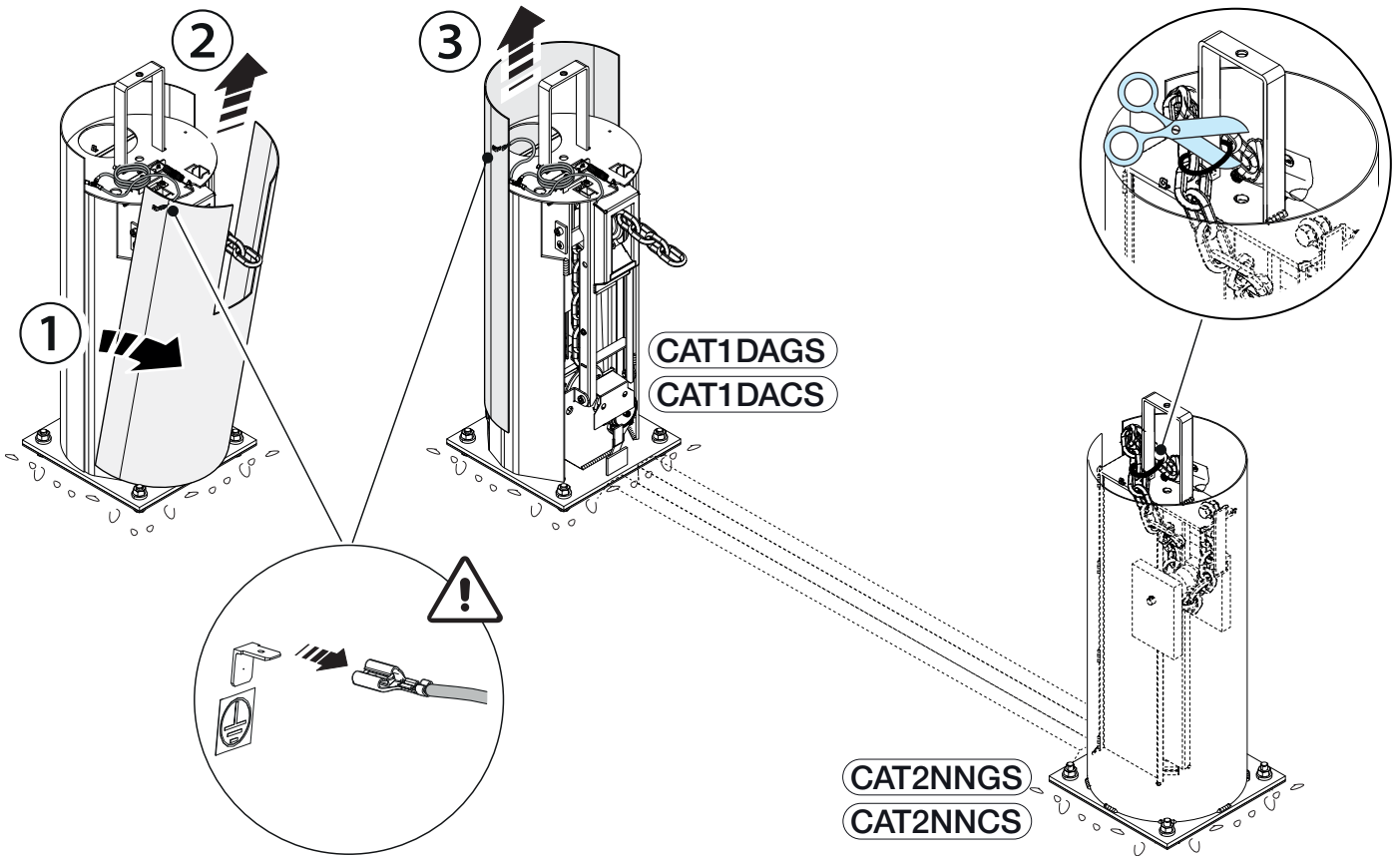

Lay the chain protection track between the two pillars. Cut off any excess.

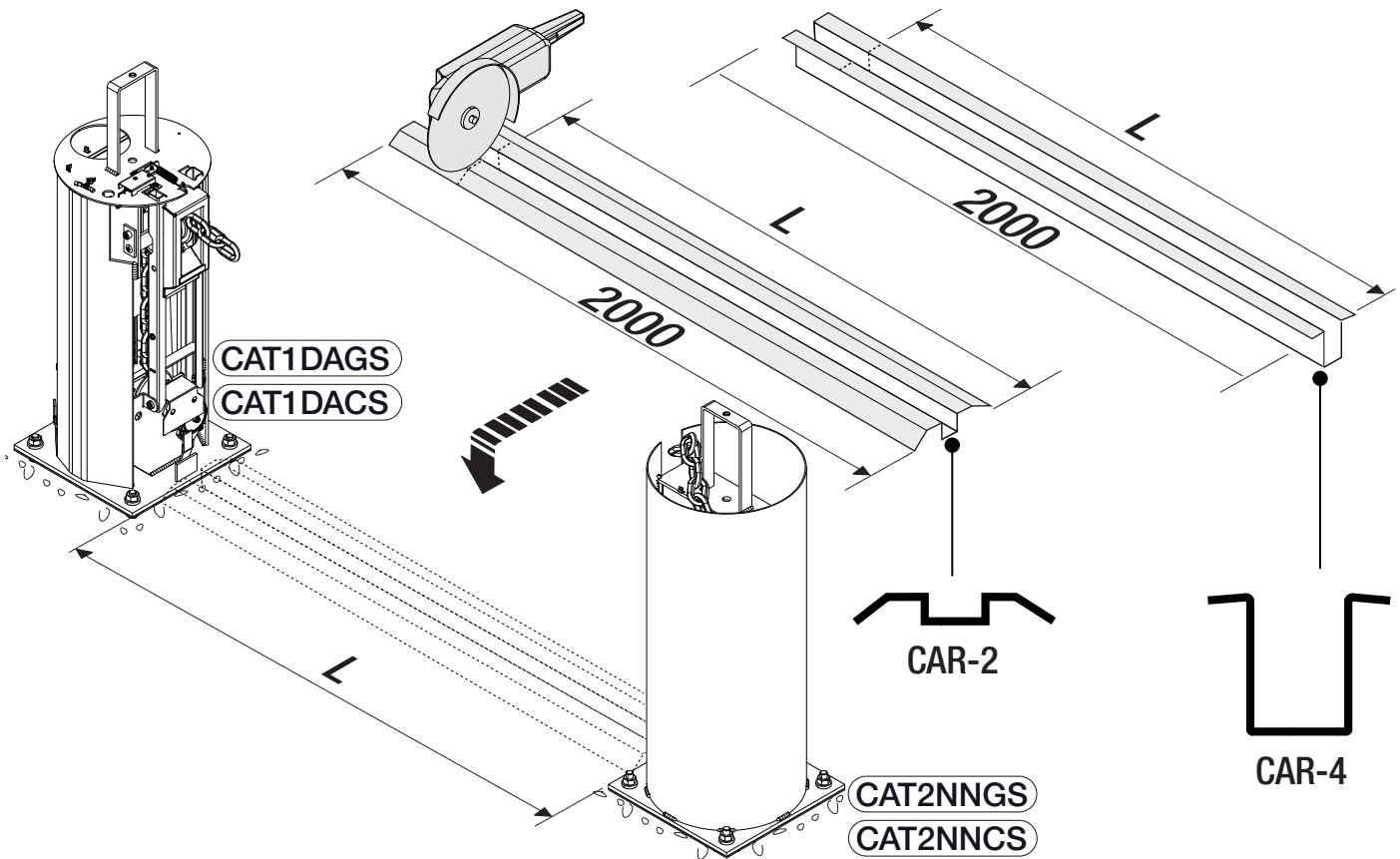

Calculate the length of barrier chain required and cut off the excess.

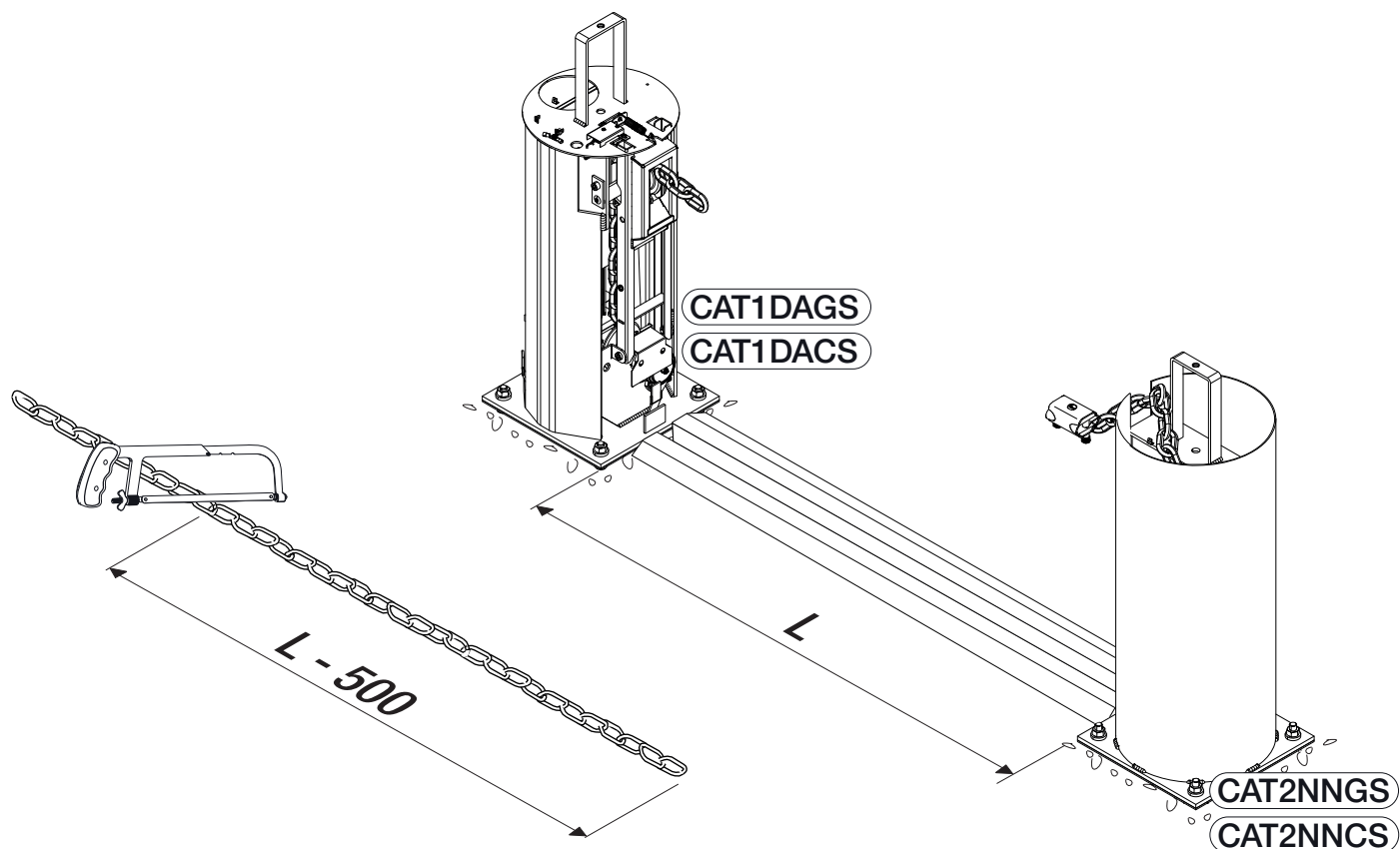

Fasten the barrier chain to the CAT1DAGS / CAT1DACS service chain using the fastening terminal.
Secure the other end to the CAT2NNGS / CAT2NNCS service chain using the lock.

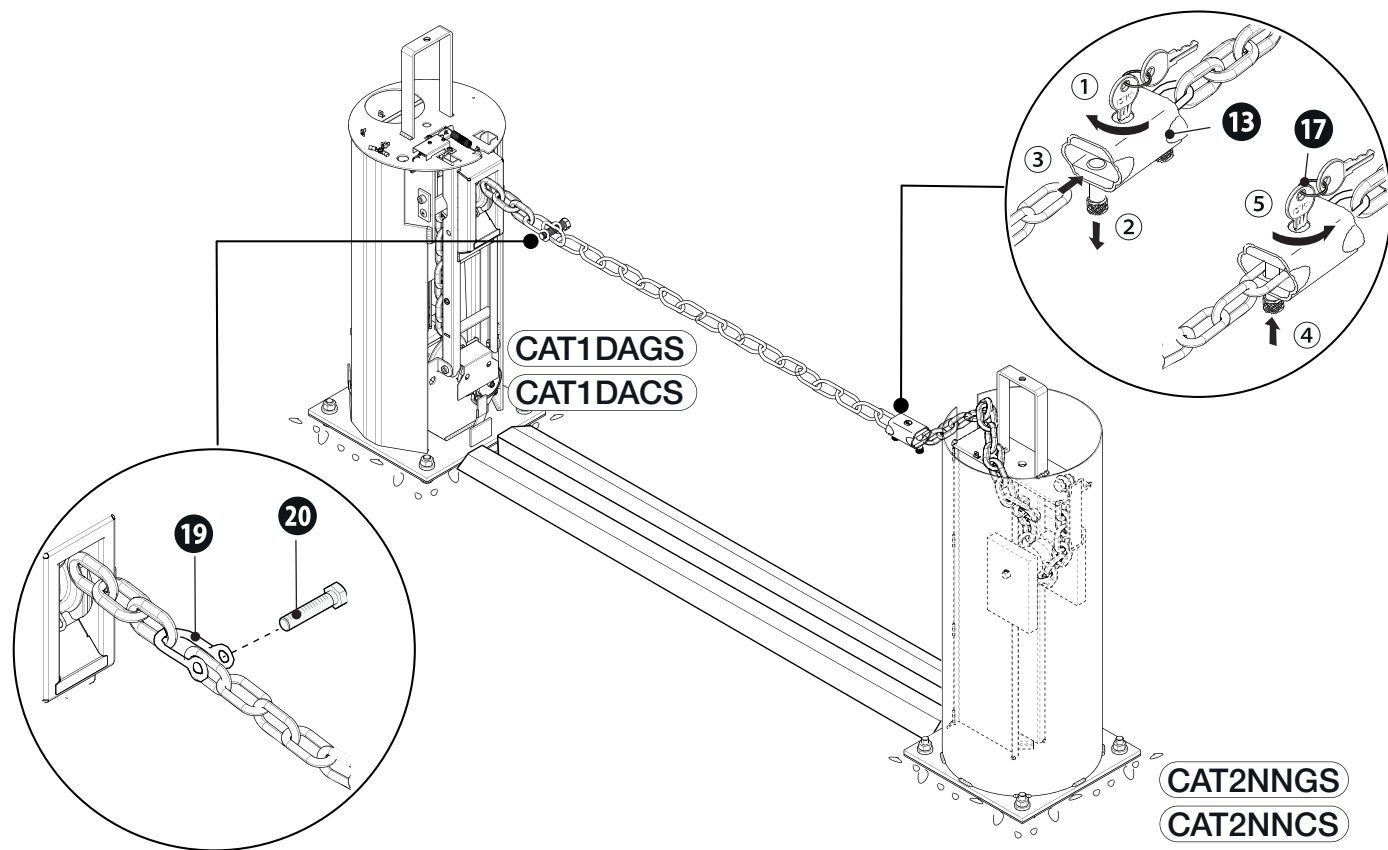

 All operational checks and final testing must be performed once the system is complete and the chain has been installed.

Establishing the limit-switch points

Remove the limit-switch assembly guard.

Limit-switch assembly

- A** Opening micro limit switch
- B** Closing micro limit switch
- C** Cam for setting the opening travel end point
- D** Cam for setting the closing travel end point

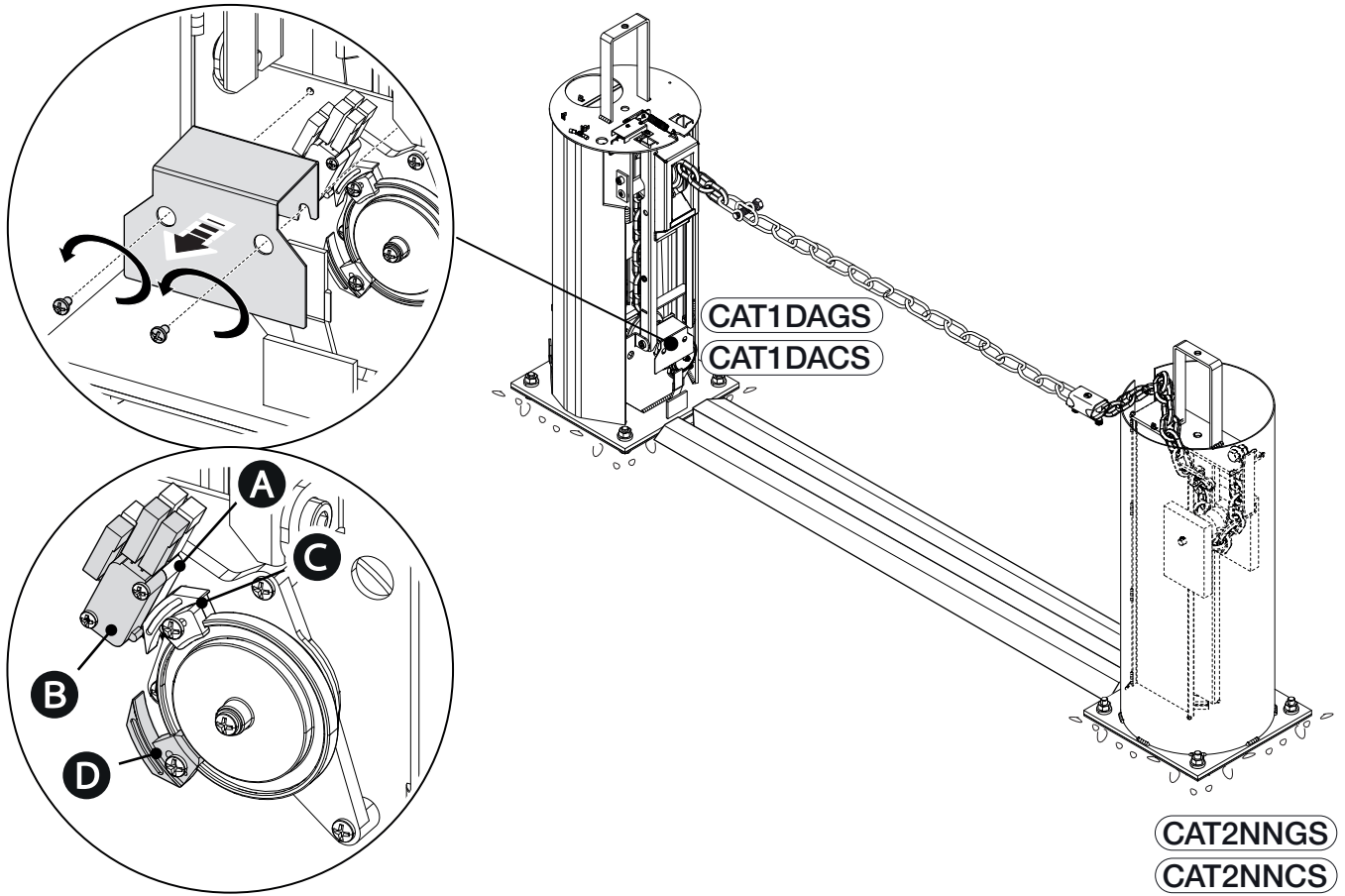

Opening limit-switch

 By default, the opening microswitch is already activated by the open limit switch cam.

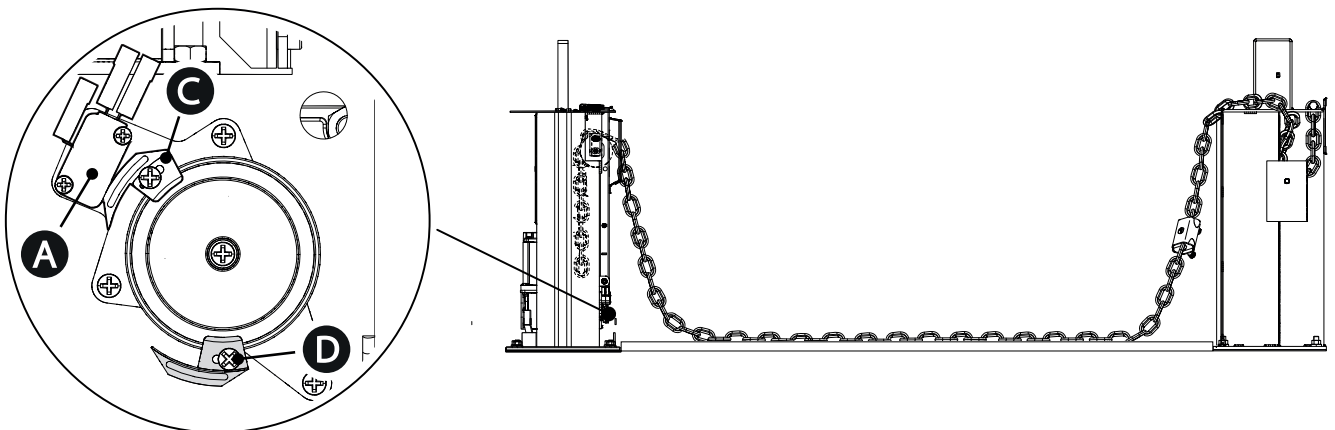

Closing safety limit switch

 The closing microswitch is used to stop the operator safely, should the chain break.

With the control panel powered, send a closing command and wait for the gearmotor to stop (amperometric sensitivity).

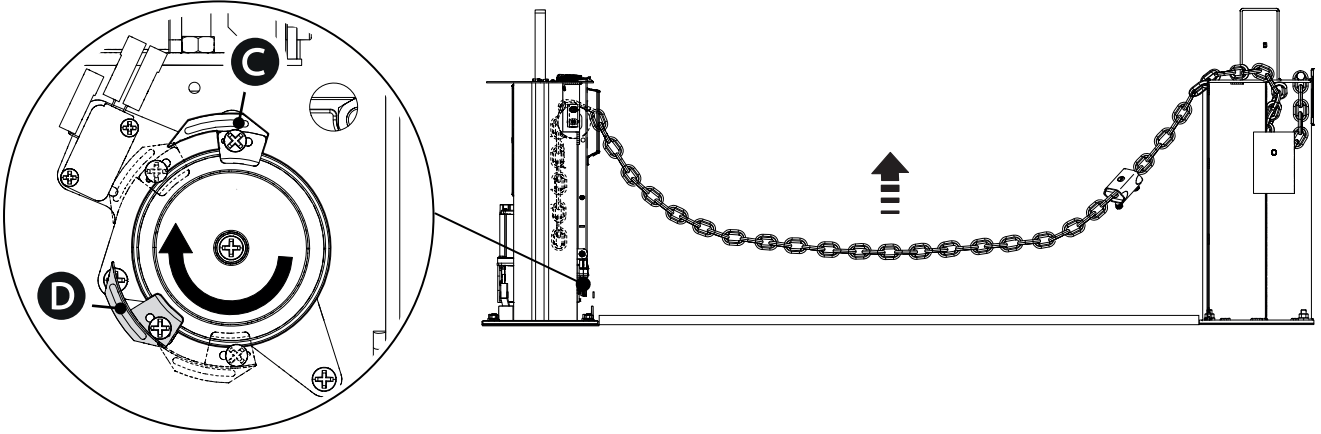

With the gearmotor stopped, position the close limit switch cam near the closing microswitch without activating it as shown.

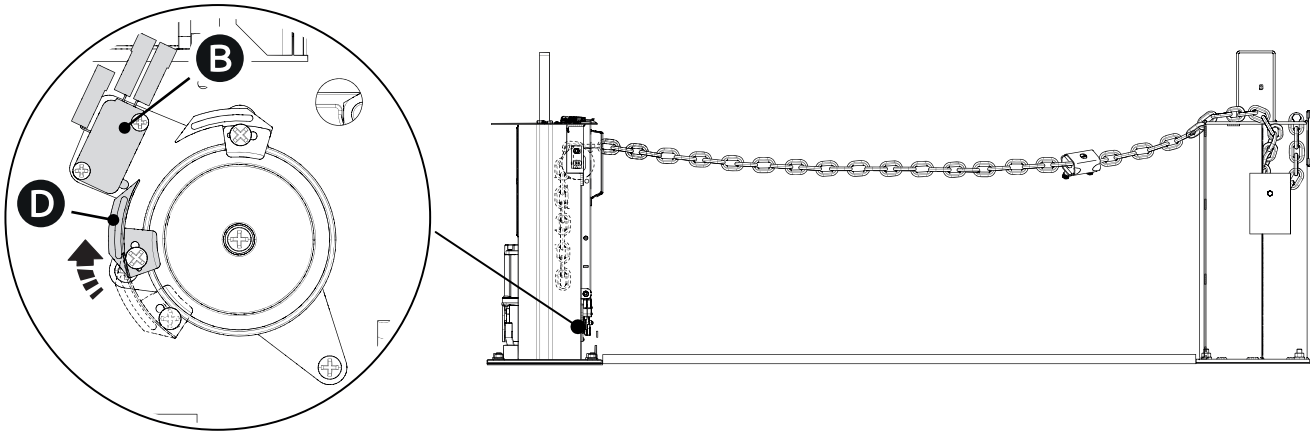

Passing the electrical cables

The electrical cables must not touch any parts that may overheat during use (such as the motor and transformer).
 Make sure that the moving mechanical parts are suitably far away from the wiring.

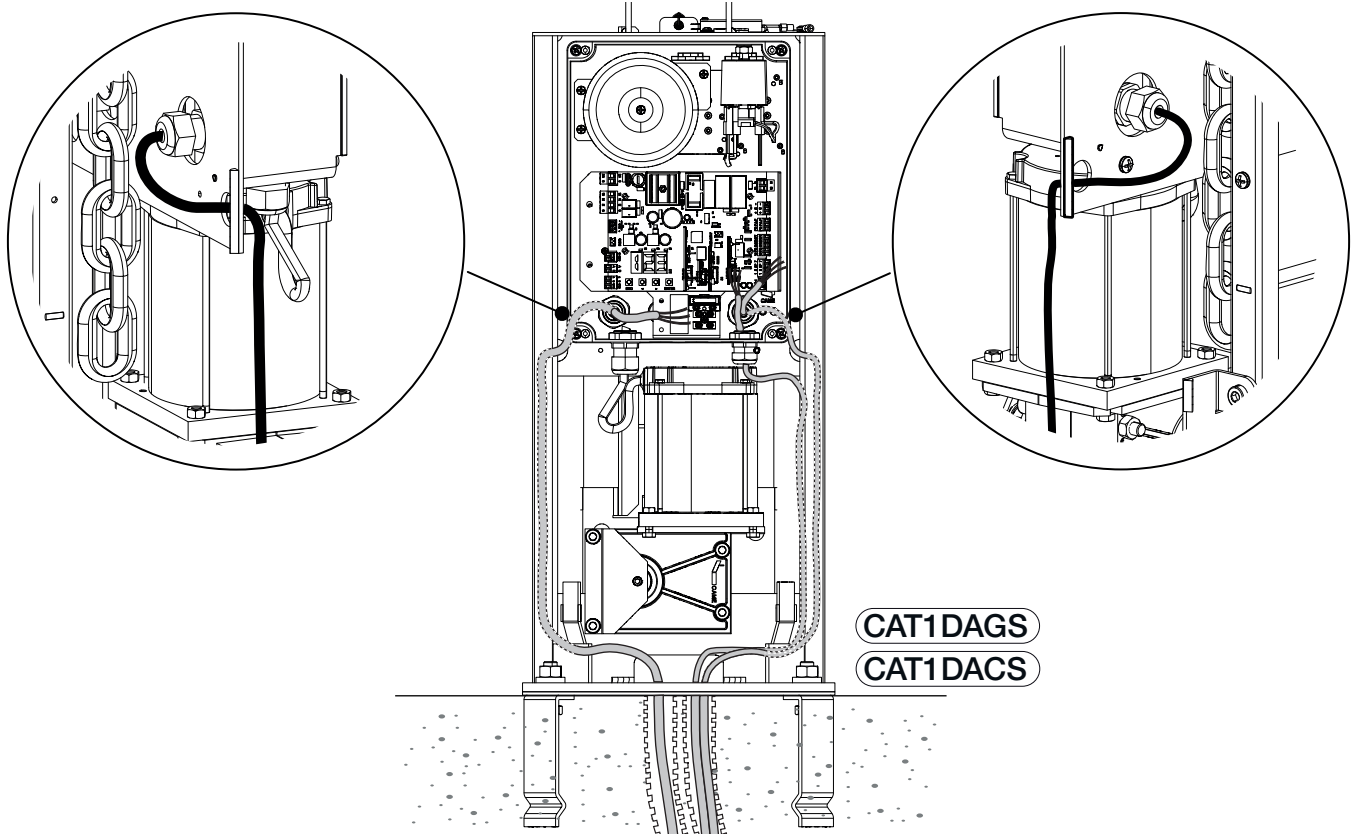

Power supply

Make sure the mains power supply is disconnected during all installation procedures.

⚠ Before working on the control panel, disconnect the mains power supply and remove the batteries, if any.

Connecting to the electrical network

- ⓕ Line fuse
- Ⓛ Phase wire
- Ⓝ Neutral wire
- Ⓧ Earth wire

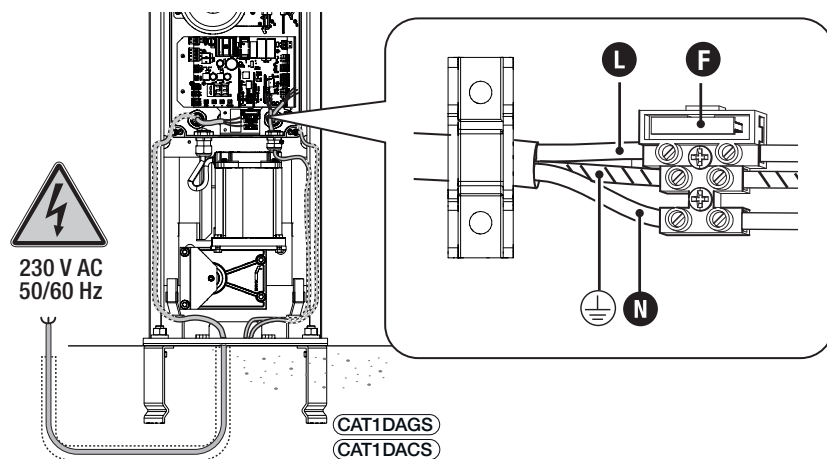

Power supply output for accessories 24 V

The output normally delivers 24 V AC.

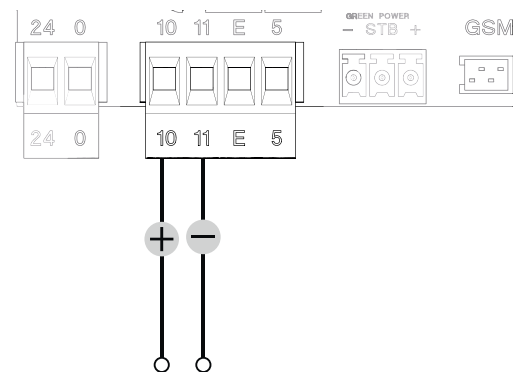

Maximum capacity of contacts

The total power of the outputs listed below must not exceed the maximum output power [Accessories]

Device	Output	Power supply (V)	Power (W)
Accessories	10-11	24 AC	40
Additional light	10-E	24 AC	25
Flashing beacon	10-E	24 AC	25
Operator status warning light	10 - 5	24 AC	3

The outputs deliver 24 V DC when the batteries start operating, if they are installed.

Command and control devices

1 Antenna with RG58 cable

Insert the AF card into the corresponding connector for remote control with transmitter.

If the chosen signalling device can be fitted with an antenna, use the terminal shown to connect it.

2 STOP button (NC contact)

This stops the operator and excludes automatic closing. Use a control device to resume movement.

When the contact is being used, it must be activated during programming.

See the [F1 – Total stop] function.

3 Control device (NO contact)

Open command

When the [F6 – Hold-to-run] function is active, a control device must be set to OPEN.

4 Control device (NO contact)

Step-by-step command

When the function [F6 - Hold-to-run] is active, a control device must be set to CLOSE.

5 Card reader

Insert the R700 card into the corresponding connector.

6 Transponder selector switch

Insert the R700 card into the corresponding connector.

7 Keypad selector

Insert the R800 card into the corresponding connector.

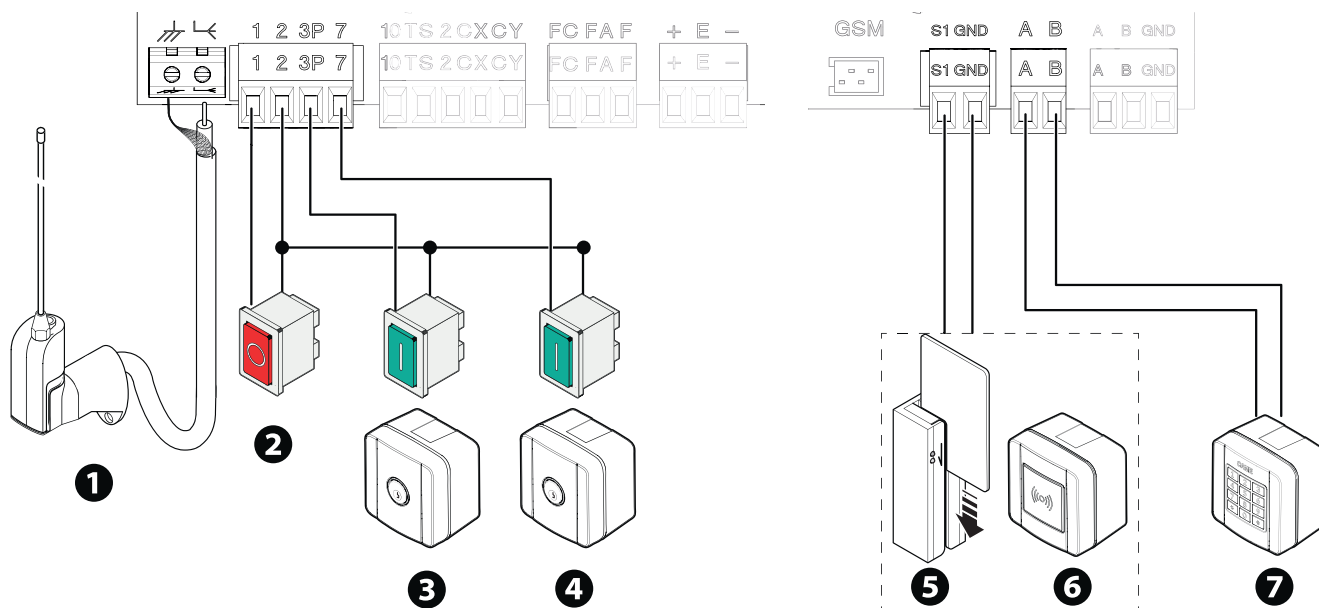

Signalling devices

1 Additional light

It increases the light in the manoeuvring area.

📖 See function [F18 - Additional light].

2 Additional flashing beacon

It flashes when the operator opens and closes.

3 Operator status warning light

It notifies the user of the operator status.

📖 See function [F10 - Passage-open warning light].

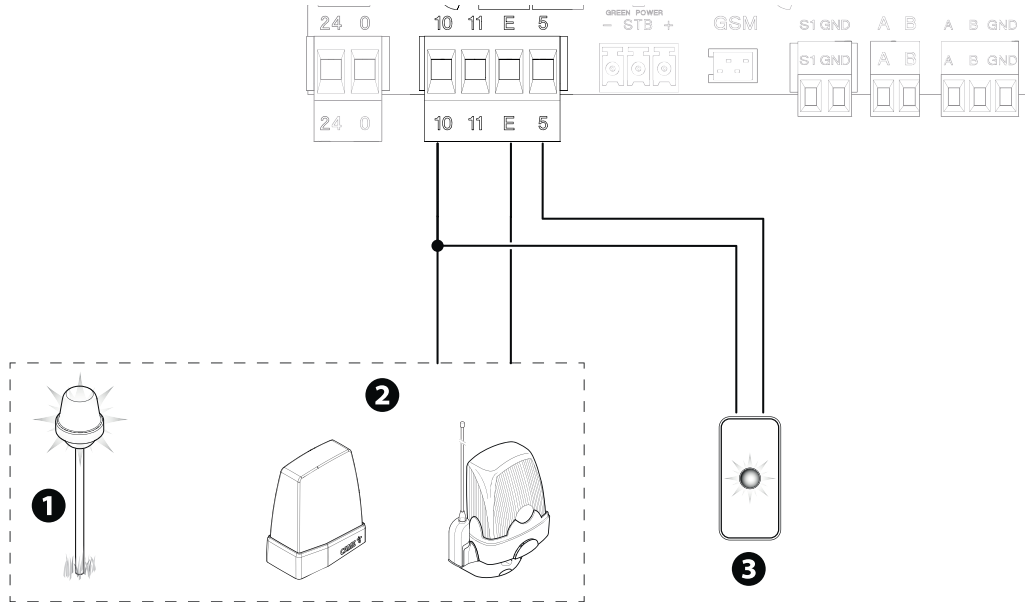

Safety devices

Built-in entrapment-prevention device

The entrapment-prevention device trips when the mobile mechanism is accidentally knocked during closing, activating the safety microswitch which inverts the movement of the chain until fully open.

The safety microswitch is already connected at the input to CX with the function of reopening during closing.

- A** Safety microswitch
- B** Mobile mechanism
- C** Safety device terminal board

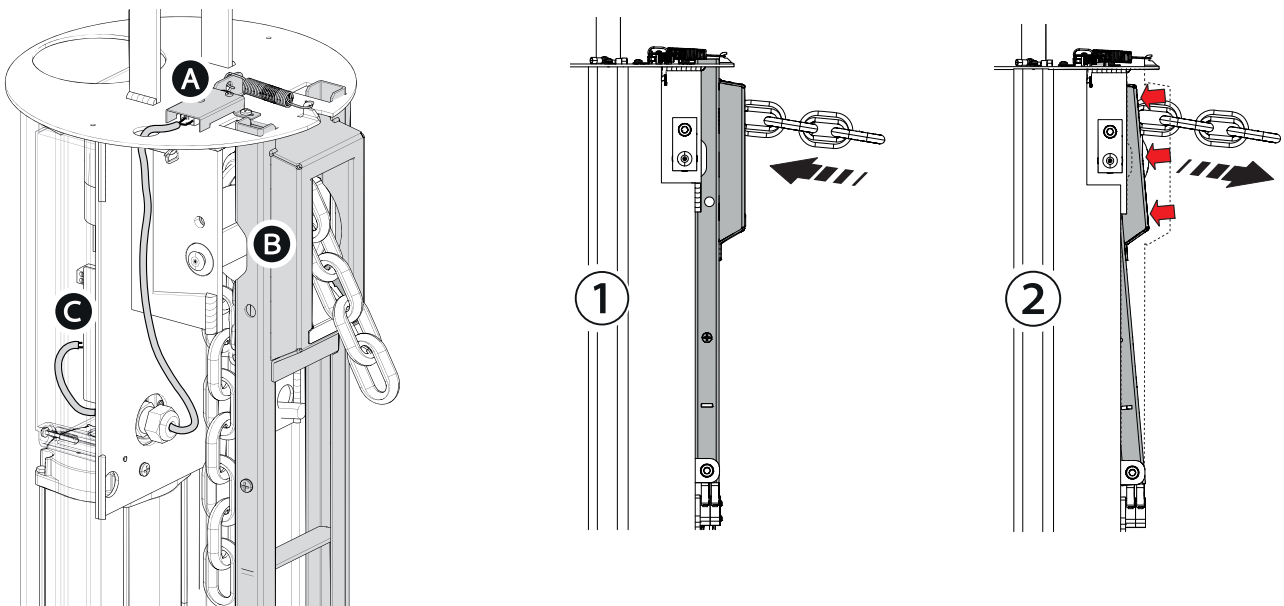

Photocells

Connect the safety devices to the CY input (NC contacts).

During programming, configure the type of action that must be performed by the device connected to the input.

If the CY contact is used, it must be configured during programming.

For systems with multiple pairs of photocells, please see the manual for the relevant accessory.

DIR photocells

Standard connection

DIR photocells

Connection with safety test

See function [F5] Safety devices test.

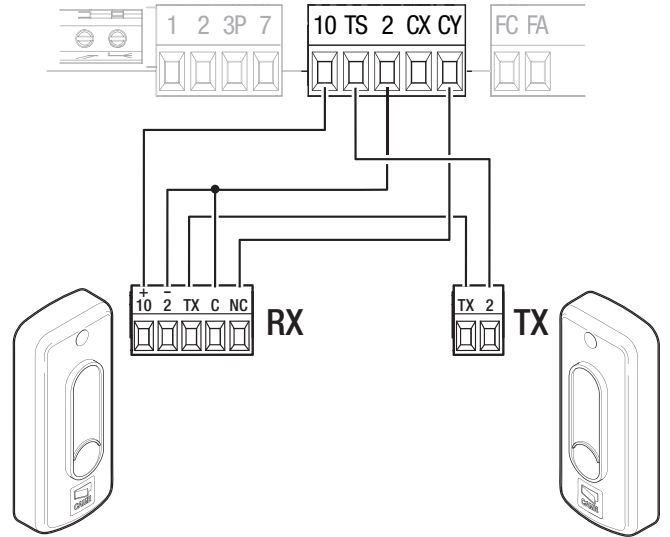
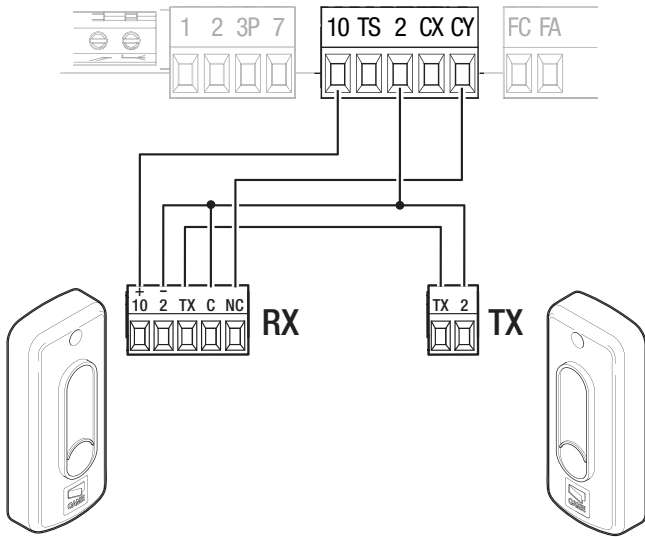

DXR/DLX photocells

Standard connection

DXR/DLX photocells

Connection with safety test

See function [F5] Safety devices test.

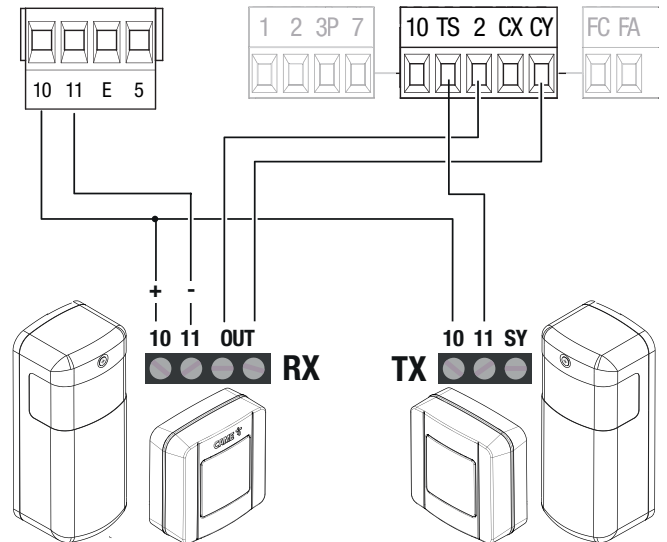
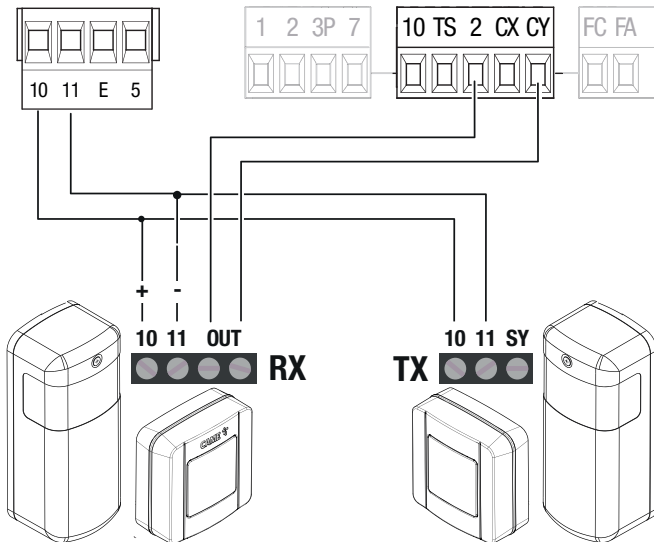

Programming button functions

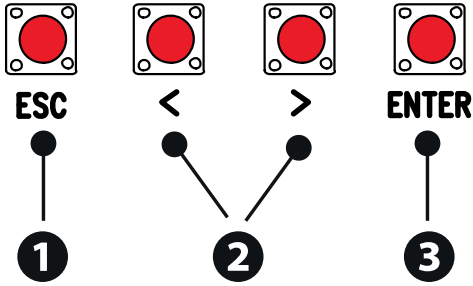
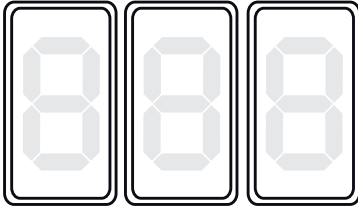

1 ESC button

The ESC button is used to perform the operations described below.
 Exit the menu
 Delete the changes
 Go back to the previous screen

2 <> buttons

The <> buttons are used to perform the operations described below.
 Navigate the menu
 Increase or decrease values

3 ENTER button

The ENTER button is used to perform the operations described below.
 Access menus
 Confirm choice

During movement, outside the menu, the ESC key stops the barrier and the <> keys open and close the barrier.

Functions menu

Total stop

This stops the operator and excludes automatic closing. Use a control device to resume movement.

F1	OFF (Default) ON
-----------	---------------------

CY input

Associate a function with the CY input.

F3	OFF (Default) C1 = Reopen while closing (photocells) C4 = Obstacle standby (photocells) C5 = Immediate closure at the travel end during opening
-----------	--

Safety devices test

Check that the photocells connected to the inputs are operating correctly, after each opening and closing command.

Run the test by connecting the photocells to the TS terminal [see paragraph on Safety devices].

F5	OFF (Default) 2 = CY
-----------	-------------------------

Hold-to-run

With the function active, the operator stops moving (opening or closing) when the control device is released.

When the function is active, it excludes all other control devices.

F6	OFF (Default) ON
-----------	---------------------

Command 2-7

Associate a command to the connected device on 2-7.

F7	0 = Step-by-step (default) - The first command is to open and the second to close. 1 = Sequential - The first command is to open, the second to STOP, the third to close and the fourth to STOP. 2 = Open 3 = Close
-----------	--

Obstacle with motor stopped

With the function active and the operator stopped, an open or close command is not performed if the safety devices detect an obstacle. The function is active when the passage is closed or open, or after a complete stop.

F9	OFF (Default) ON
-----------	---------------------

Open warning light

It notifies the user of the operator status.

F10	0 = Warning light on (default) - The light stays on when the operator is moving or the passage is open. 1 = Warning light flashing - The warning light flashes every half a second when the passage is opening and stays on when the passage is open. The light flashes every second when the passage is closing, and remains off when the passage is closed.
------------	--

Sensor type

Choose the type of access device.

F14	1 = Keypad selector (default) 0 = Transponder selector or magnetic card reader
------------	---

Additional light

Choose the operating mode of the lighting device connected to output 10-E.

 The function appears only if the [Automatic closure] function is deactivated.

F18	0 =Flashing beacon (Default) 1 = Cycle light - The lamp stays on during the manoeuvre.  The light remains off if an automatic closing time is not set.
------------	---

Automatic closure

Set the time before automatic closure, once the opening travel end point has been reached.

 The function does not work if any of the safety devices are triggered when an obstacle is detected, or after a complete stop, or during a power outage.

F19	OFF (Default) From 1 to 180 seconds
------------	--

Pre-flashing time

Adjust the time for which the beacon is activated before each manoeuvre.

F21	OFF (Default) 1 to 10 seconds
------------	----------------------------------

Operating time

Set the gearmotor working time during opening and closing.

F22	5 to 30 seconds (Default 20 seconds)
------------	--------------------------------------

Gate travel speed

Set the travel speed (percentage of maximum speed).

F28	50% to 100% (Default 100%)
------------	----------------------------

Travel sensitivity

It adjusts the obstacle detection sensitivity during the gate travel.

F34	10% to 100% (Default 100%)  10% = minimum thrust and high obstruction sensitivity 100 % =maximum thrust and low obstruction sensitivity
------------	--

Save data

Save user data, timings and configurations to the memory device (memory roll).

 The function is displayed only when a memory roll card is inserted into the control board.

F50	OFF (Default) ON (Run operation)
------------	-------------------------------------

Read data

Upload user data, timings and configurations to the memory device (memory roll).

 The function is displayed only when a memory roll card is inserted into the control board.

F51	OFF (Default) ON (Run operation)
------------	-------------------------------------

CRP address

Assign a unique identification code (CRP address) to the control board.

 The function is used where there are multiple operators connected to the same communication BUS using the CRP protocol.

F56	from 1 to 255
------------	---------------

RSE speed

Set the remote connection system communication speed on the RSE port.

F63	0 = 1200 bps 1 = 2400 bps 2 = 4800 bps 3 = 9600 bps 4 = 14400 bps 5 = 19200 bps 6 = 38400 bps (default) 7 = 57600 bps 8 = 115200 bps
------------	--

New user

Register up to a maximum of 250 users and assign a function to each one.

 The operation can be carried out by using a transmitter or another control device. The boards that manage the control devices (AF - R700 - R800) must be inserted into the connectors.

U1	1 = Step-by-step - The first command is to open and the second to close. 2 = Sequential - The first command is to open, the second to STOP, the third to close and the fourth to STOP. 3 = Open Choose the function to be assigned to the user. Press ENTER to confirm. The free position in the memory is shown intermittently for a maximum of 10 seconds. During this phase, send the code from the control device. Repeat the procedure to add other users.
-----------	---

Remove user

Remove one of the registered users.

U2	ON OFF Use the arrows to choose the number associated with the user you want to remove. No. 1 > 250 Alternatively, the control device associated with the user you want to remove can be activated. Press ENTER to confirm.  "CLr" will appear to confirm deletion.
-----------	--

Remove all

Remove all registered users.

U3	OFF (Default) ON
-----------	---------------------

Radio decoding

Choose the type of radio coding for the transmitters enabled to control the operator.

If you choose the type of radio coding for the transmitters [Rolling code] or [TW key block], any transmitters with a different type of radio coding saved previously will be deleted.

U4	1 = All decoding (default) 2 = Rolling code 3 = TW key block
-----------	--

Self-Learning Rolling

Save a new rolling code transmitter by activating acquisition from a rolling code transmitter that has already been saved. The saving and acquisition procedures are explained in the transmitter manual.

U8	OFF (Default) ON
-----------	---------------------

Parameter reset

Restore the factory configurations except for:[users]

A4	OFF (Default) ON
-----------	---------------------

Manoeuvre counter

View the number of operator manoeuvres.

001 = 100 manoeuvres / 010 = 1000 manoeuvres / 100 = 10000 manoeuvres / 999 = 99900 manoeuvres / CSt = maintenance job

The number of manoeuvres is the number shown multiplied by 100.

A5	CSt = Maintenance work 001 = 100 manoeuvres 010 = 1000 manoeuvres 100 = 10000 manoeuvres 999 = 99900 manoeuvres
-----------	---

FW version

Display the firmware version.

H1	
-----------	--

Import/export data

Save user data and system configuration data on a MEMORY ROLL card.

The stored data can be reused for another control board of the same type to carry across the same configuration.

Before inserting and removing the MEMORY ROLL card, DISCONNECT THE MAINS POWER SUPPLY TO THE LINE.

- 1** Insert the MEMORY ROLL card into the corresponding connector on the control board.
- 2** Press the "Enter" button to access programming.
- 3** Use the arrows to choose the desired function.

The functions are displayed only when a MEMORY ROLL card is inserted.

[F50] - Save data

Save user data, timings and configurations to the memory device (memory roll).

[F50] - Read data

Upload user data, timings and configurations to the memory device (memory roll).

Once the data have been saved and loaded, remove the MEMORY ROLL card.

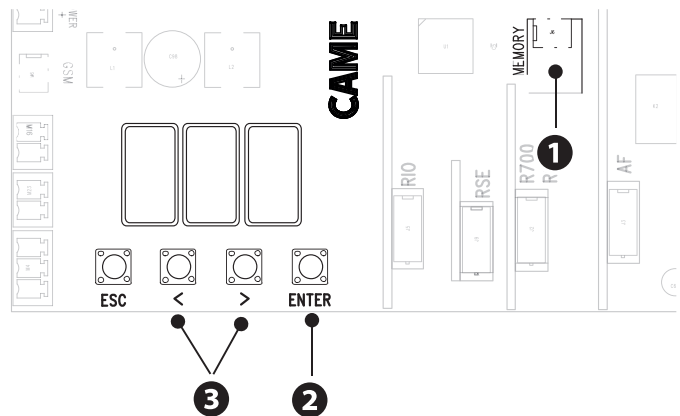

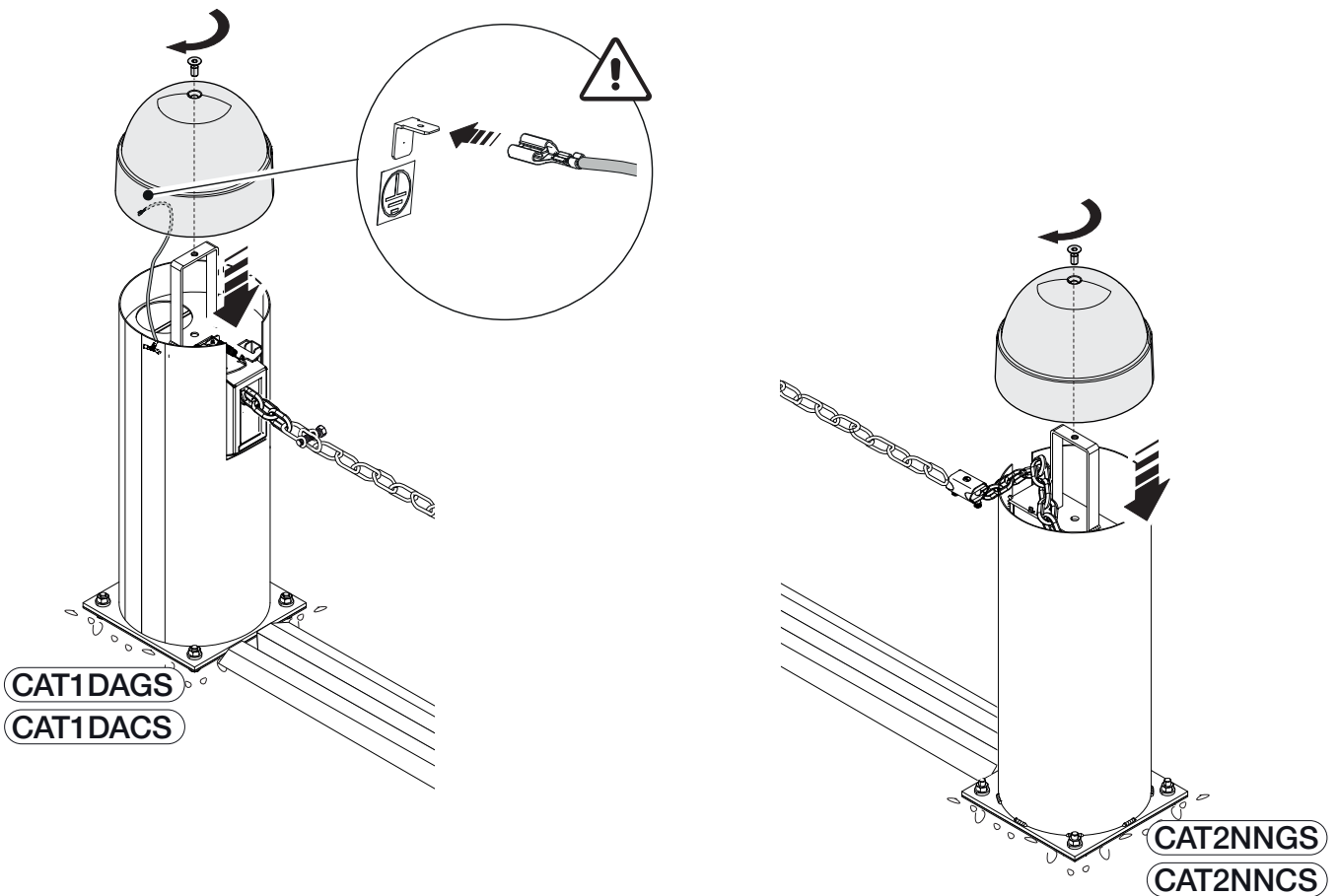
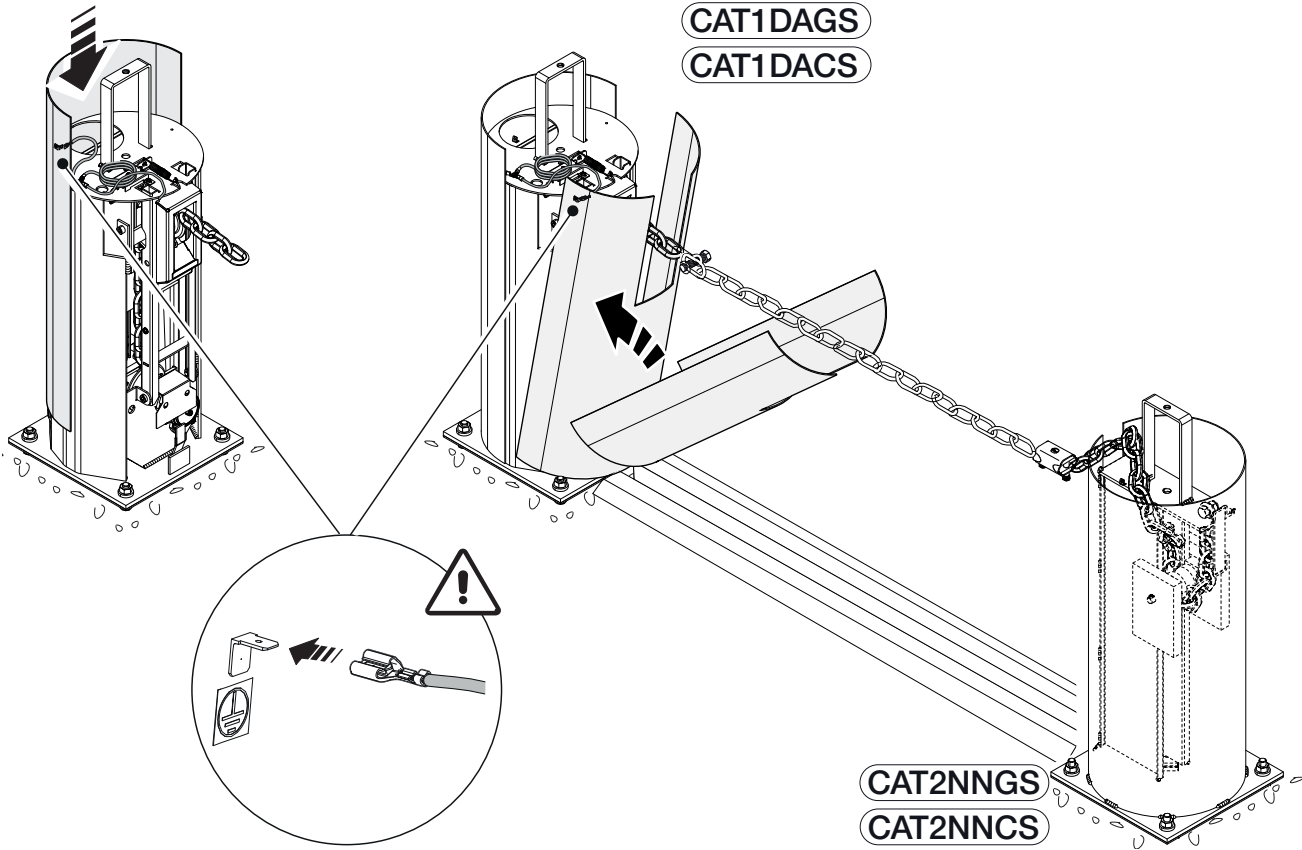

MCBF

Models	CAT
Chain 9 mm 8 m	50.000
Chain 5 mm 16 m	-10%

 The MCBF value relates to the barrier only and does not refer to any applicable accessories.

 Before carrying out any cleaning or maintenance, or replacing any parts, disconnect the device from the power supply.

 This document informs the installer of the checks that must be carried out during maintenance.

 For information on correct installation and adjustments, please see the product installation manual.

 For information on choosing products and accessories, please see our product catalogue.

 Every 6 months of operation, perform the mandatory maintenance work indicated below.

Perform a general and complete check of the tightness of the nuts and bolts.

Grease all of the moving mechanical parts.

Check the warning and safety devices are working properly.

Check the entrapment-prevention safety microswitch is working correctly.

Check for any wear on the moving mechanical parts and check that they are working properly.

Check the cables are intact and connected correctly.

ERROR MESSAGES

E4	Service test failure error
E11	The maximum number of obstacles detected consecutively has been exceeded
E13	Limit switch input error or both limit switches open
E15	Incompatible transmitter error

NOTICES

C0	Wire contact 1-2 (NC) is open.
C7	Wire contact 2-CX (NC) is open.
C1, C4, C5	The photocell wire contact 2-CY (NC) is open.



CAME 

CAME.COM

CAME S.P.A.

Via Martiri della Libertà, 15
31030 Dosson di Casier
Treviso – Italy
Tel. (+39) 0422 4940
Fax (+39) 0422 4941